

PROGRAMMA MISCELAZIONE BAGNO  
BATH MIXING PROGRAM  
PROGRAMME DU MITIGEUR POUR LA SALLE DE BAIN  
BAD-MISCHUNGSPROGRAMM  
PROGRAMA MEZCLADORES BAÑO  
ПРОГРАММА СМЕСИТЕЛЕЙ ДЛЯ ВАННОЙ  
ΛΟΥΤΡΟ ΠΟΥ ΑΝΑΜΙΓΝΥΕΙ ΤΟ ΠΡΟΓΡΑΜΜΑ  
浴室混水产品

# HI-FI

Art. 63041

Art. 63043

**GESSI** THE  
PRIVATE  
WELLNESS  
COMPANY®



GESSI SpA  
Parco Gessi - 13037 Serravalle Sesia  
(Vercelli) ITALY  
Tel. +39 0163 454111  
Fax +39 0163 459273  
[www.gessi.com](http://www.gessi.com) - [gessi@gessi.it](mailto:gessi@gessi.it)

### ART. 63041

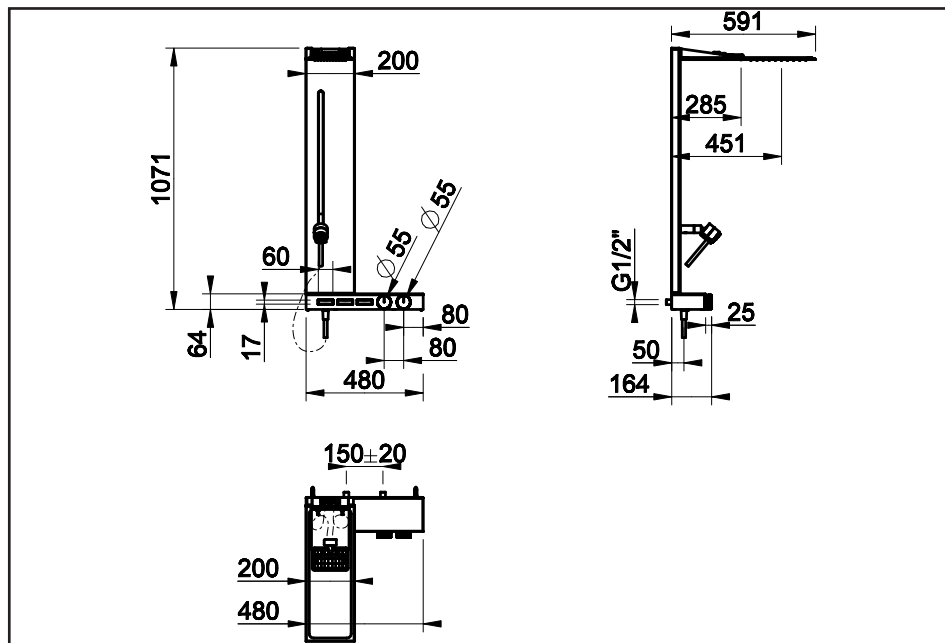

### ART. 63043

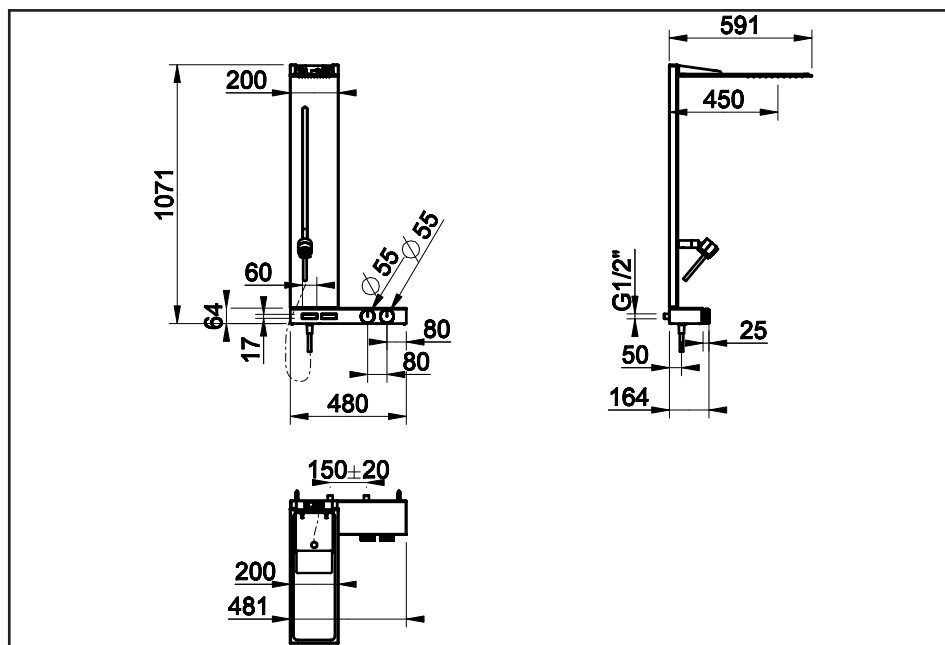

### **Prima dell'installazione e messa in funzione**

**Attenzione!** I tubi d'alimentazione devono essere sciacquati con cura prima dell'installazione del dispositivo, in modo che non rimangano trucioli, residui di saldatura o canapa, o altre impurità all'interno dei tubi. Attraverso tubazioni non sciacquate a fondo o attraverso la rete idrica generale, nel dispositivo possono entrare corpi estranei in grado di danneggiare guarnizioni/o-ring. Si raccomanda pertanto di dotare anche l'impianto generale di filtri.

#### **CARATTERISTICHE TECNICHE:**

- Blocco di sicurezza a 38 °C.
- Temperatura min. di esercizio 3 °C. - consigliata 15 °C. - FREDDA.
- Temperatura max di esercizio 80 °C. - consigliata 65 °C. - CALDA.
- Differenziale termico consigliato 50 °C.
- Sistema di sicurezza con blocco dell'erogazione in caso di mancanza di una delle due acque.
- Pressione massima d'esercizio 5 bar
- Pressione d'esercizio consigliata 3 bar (in caso di pressione dell'acqua superiore ai 5 bar si consiglia l'installazione di riduttori di pressione)

#### **FUNZIONAMENTO:**

- Sia con scaldabagni a gas che elettrici ad accumulo.
- Impianti centralizzati.
- Caldaie murali.
- Filtri per il trattamento delle impurità.

**Attenzione: consultare il proprio idraulico di fiducia per la scelta del dispositivo di riscaldamento dell'acqua più idoneo.**

### **Before installation and setting to work**

**Attention!** The feeding pipes have to be rinsed carefully before the installation of the device so that there won't remain shavings, sealing or hemp residues, or other impurities inside the pipes. Through pipes not thoroughly rinsed or through the general water network, in the device foreign bodies can enter that could damage gaskets /o-ring. So filters should be installed also on the general system.

#### **TECHNICAL FEATURES:**

- Safety lock at 38 °C.
- Minimum working temperature 3 °C. - recommended 15 °C. - COLD.
- Maximum working temperature 80 °C. - recommended 65 °C. - HOT.
- Recommended thermal differential 50 °C.
- Safety system with flow stop in case of lack of one of the two waters.
- Maximum working pressure 5 bar
- Recommended working pressure 3 bar (in case of water pressure higher than 5 bar it is recommended to install pressure reducers)

#### **OPERATION:**

- Either with gas or electric accumulation boilers.
- Centralised systems.
- Wall boilers.
- Filters for impurity holding.

**Warning: contact the plumber for the choice of the best water heating device.**

### **Avant l'installation et la mise en fonction**

**Attention!** Les tuyaux d'alimentation doivent être rincés avec soin avant l'installation du dispositif, de sorte que ils ne restent pas de copeaux, des restes de soudage ou de chanvre, ou d'autres impuretés à l'intérieur des tuyaux. A travers les conduites non rincées à fond ou à travers le réseau hydrique général, dans le dispositif peuvent entrer des corps étrangers à même de détériorer les gaines/o-ring. On recommande ainsi d'installer des filtres également sur le système général.

#### **CARACTÉRISTIQUES TECHNIQUES:**

- Bloc de sécurité à 38 °C.
- Température min. d'exercice 3 °C. - conseillée 15 °C. - FROIDE.
- Température max. d'exercice 80 °C. - conseillée 65 °C. - CHAUDE.
- Différentiel thermique conseillé 50 °C.
- Système de sécurité avec le bloc de la distribution en cas de manque d'une des deux eaux.
- Pression maximum d'exercice 5 bar
- Pression d'exercice conseillée 3 bar (en cas de pression de l'eau supérieure aux 5 bar nous conseillons l'installation de réducteurs de pression)

#### **FONCTIONNEMENT:**

- Soit avec des chauffe-eaux à gaz, électriques à accumulation.
- Installations centrales.
- Chaudières au mur.
- Filtres pour la rétention des impuretés.

**Attention: consulter le plombier pour le choix du dispositif de réchauffement de l'eau le plus approprié.**

### Vor der Installation und Inbetriebnahme

**Achtung!** Bevor die Vorrichtung zu installieren, bitte spülen Sie die Zuleitungsröhre sorgfältig aus, um alle Spannen, Schweiß- und Hanfrückstände bzw. alle Verunreinigungen vom Inneren der Röhre zu entfernen. Durch nicht sorgfältig gespülte Rohrleitungen bzw. durch das allgemeine Wassernetz können Fremdkörper in den Korpen eintreten, die die Dichtungen bzw. die O-Ringe beschädigen können. Es ist dann empfehlenswert, die allgemeine Anlage mit Filtern auszustatten.

#### **TECHNISCHE EIGENSCHAFTEN:**

- Sicherheitsblockierung bei 38 °C.
- Minimale Betriebstemperatur 3 °C. - empfehlenswert 15 °C. - KALT
- Maximale Betriebstemperatur 80 °C. - empfehlenswert 65 °C. - WARM
- Empfohlenes Thermodifferential 50 °C.
- Sicherheitssystem zum Unterbrechen der Wasserabgabe, sollte eine der beiden Wasserzuleitungen ausfallen
- Maximaler Betriebsdruck 5 bar
- Empfohlener Betriebsdruck 3 bar (sollte der Wasserdruck einen Wert von 5 bar überschreiten, empfiehlt es sich Druckminderventile zu installieren)

#### **FUNKTIONSTÄTIGKEIT:**

- Sowohl mit Gasbadeofen, als auch mit elektrischen Heißwasserspeichern.
- Zentralisierte Anlagen.
- Wandheizkessel.
- Filter zum Zurückhalten von Verunreinigungen.

**Achtung: zur Wahl der best anpassenden Wasserheizvorrichtung, bitte wenden Sie sich an Ihren Vertrauensinstallateur.**

### Antes de la instalación y la puesta en función

**¡Cuidado!** Los tubos de alimentación tienen que ser enjuagados escrupulosamente antes de instalar el dispositivo de manera que no haya virutas, residuos de soldadura o cáñamo u otras impurezas al interior de los tubos. A través de los tubos no perfectamente enjuagados o de la red hídrica general pueden entrar en el dispositivo unos cuerpos extraños que pueden dañar guarniciones/o-rings. Les recomendamos por lo tanto que instalen los filtros en la planta general también.

#### **CARACTERÍSTICAS TÉCNICAS:**

- Bloqueo de seguridad a 38 °C.
- Temperatura mín. de ejercicio 3 °C. - recomendada 15 °C. - FRÍA.
- Temperatura máx. de ejercicio 80 °C. - recomendada 65 °C. - CALIENTE.
- Diferencial térmico recomendado 50 °C.
- Sistema de seguridad con bloqueo de seguridad en caso de falta de una de las dos aguas.
- Presión máxima de ejercicio 5 bar
- Presión de ejercicio aconsejada 3 bar (en caso de presión del agua superior a los 5 bar, les aconsejamos instalar unos reductores de presión)

#### **FUNCIONAMIENTO:**

- Con calderas tanto de gas como eléctricos por acumulación.
- Instalaciones centralizadas.
- Calderas murales.
- Filtros para la retención de las impurezas.

**Cuidado: consúltense con su fontanero para elegir el dispositivo de calefacción del agua más adecuado.**

### Перед установкой и началом использования

**Внимание!** Перед установкой смесителя необходимо тщательно промыть водопроводные трубы, чтобы в них не оставались стружка, шлак от сварки, лен или другие посторонние тела. Через плохо промытые водопроводные трубы или через общую водопроводную сеть в смеситель могут попасть посторонние тела, способные повредить уплотнения и уплотнительные кольца. Поэтому, рекомендуется оснастить фильтрами также и общую систему.

#### **ТЕХНИЧЕСКИЕ ХАРАКТЕРИСТИКИ:**

- Предохранительное ограничение температуры на 38 °C.
- Минимальная рабочая температура 3°C. - рекомендованная 15°C. - ХОЛОДНАЯ.
- Максимальная рабочая температура: 80°C. - рекомендованная 65°C. - ГОРЯЧАЯ.
- Рекомендуемая разница температуры: 50 °C.
- Предохранительная система с перекрытием подачи в случае отсутствия холодной или горячей воды.
- Максимальное рабочее давление: 5 бар
- Рекомендованное рабочее давление 3 бар (в случае давления воды, превышающего 5 бар, рекомендуется установка редукторов давления).

#### **РАБОТА:**

- Как с газовыми водонагревателями, так и с электроводонагревателями накопительного типа,
- Централизованные системы,
- Настенные котлы,
- Фильтры-ловители для удержания загрязненности.

**Внимание: для выбора наиболее пригодного средства нагрева воды обращайтесь к вашему сантехнику.**

**Πριν από την εγκατάσταση και έναρξη της λειτουργίας.**

**Προσοχή!** Οι σωλήνες τροφοδοσίας πρέπει να ξεπλένονται προσεχτικά πριν από την εγκατάσταση της μπαταρίας προκειμένου να αποφευχθεί η παρουσία ψημάτων, υπολειμμάτων συγκολλητικής ουσίας ή σκουπιδιών, ή άλλων ακαθαρσιών μέσα στους σωλήνες. Μέσα από όχι τέλεια καθαρισμένους σωλήνες ή μέσα από το γενικό δίκτυο παροχής νερού, στην μπαταρία μπορεί να εισχωρήσουν ξένα σώματα τα οποία μπορούν να προκαλέσουν ζημιά στα παρεμβύσματα / στους δακτύλιους κυκλικής διατομής. Έτσι λοιπόν θα πρέπει να τοποθετηθούν φίλτρα στο γενικό σύστημα.

**ΤΕΧΝΙΚΑ ΧΑΡΑΚΤΗΡΙΣΤΙΚΑ:**

- Εμπλοκή ασφαλείας στους 38 °C.
- Ελάχιστη θερμοκρασία λειτουργίας 3 °C. - συνιστώμενη 15 °C. - ΚΡΥΟ.
- Μέγιστη θερμοκρασία λειτουργίας 80 °C. - συνιστώμενη 65 °C. - ΖΕΣΤΟ.
- Συνιστώμενο θερμικό διαφορικό 50 °C.
- Σύστημα ασφαλείας με εμπλοκή της παροχής σε περίπτωση απουσίας του ενός από τα δύο νερά.
- Μέγιστη πίεση λειτουργίας 5 bar
- Συνιστώμενη πίεση λειτουργίας 3 bar (σε περίπτωση πίεσης του νερού μεγαλύτερη από 5 bar συνιστάται η τοποθέτηση μειωτήρων πίεσης)

**ΛΕΙΤΟΥΡΓΙΑ:**

- Είτε με θερμώσιμους αερίους είτε με ηλεκτρικούς συσσωρευσης.
- Κεντρικές μονάδες.
- Λέβητες τοίχου.
- Φίλτρα για την συγκράτηση των ακαθαρσιών.

***Προσοχή: συμβουλευτείτε τον υδραυλικό της εμπιστοσύνης σας για την επιλογή της πιο κατάλληλης διάταξης θέρμανσης του νερού.***

**在安装和使用前**

**小心!** 安装本设备之前需要仔细清洗水管，确保管道里面不残留金属屑、焊接后的残渣或麻丝，或者是其他脏物。异质也能通过未深度冲洗的水管或更广义的水网管道进入装置，从而损坏垫圈/O形密封圈。为此建议为总水管网配置过滤器。

**技术参数:**

- 38° C 安全模块
- 最小工作温度3° C-建议温度15° C—冷水。
- 最大工作温度80° C-建议温度65° C—热水。
- 建议温差为50° C。
- 缺少冷水或热水时启用停止出水的安全系统。
- 最大工作压力为5巴
- 建议采用的工作压力为3巴（如果水压超过5巴建议安装减压阀）

**运行:**

- 可用燃气热水器或蓄热式电热水器。
- 中央设备系统。
- 壁挂式锅炉。
- 杂质处理过滤器。

***注意: 请咨询可信赖的水工以选择最合适的水加热设备。***

**ATTENZIONE: l'articolo è provvisto di componenti magnetici.**

**WARNING: item with magnetic components.**

**ATTENTION : l'article est fourni avec des composants magnétiques.**

**ACHTUNG: Der Artikel ist mit magnetischen Bestandteilen versehen.**

**CUIDADO: al artículo viene provvisto de componentes magnéticos.**

**ОСТОРОЖНО: изделие комплектовано магнитными компонентами.**

**ΠΡΟΣΟΧΗ: το προϊόν διαθέτει μαγνητικά εξαρτήματα.**

**注意: 本货号产品中有磁性部件。**

**ONLY FOR ART. 63043**

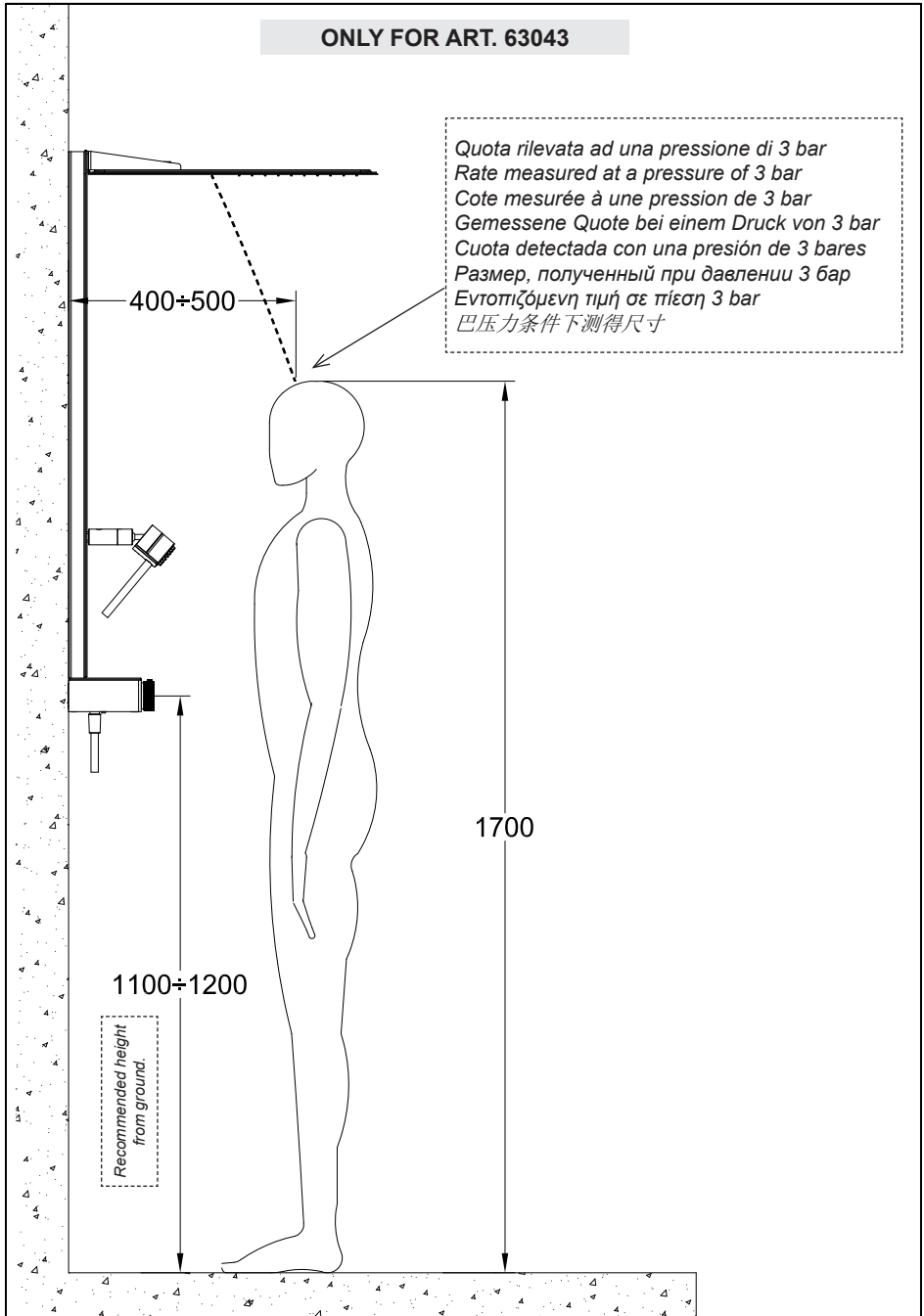



**ATTENZIONE:** la rappresentazione dell'installazione del miscelatore termostatico è stata basata solo sull'articolo a 2 uscite essendo la medesima per tutti i prodotti precedentemente elencati.

**WARNING:** the representation of the installation of the thermostatic mixer is based only on item with 2 outlets since it is the same for all previously mentioned products.

**ATTENTION:** la représentation de l'installation du mitigeur thermostatique se base seulement sur l'article à 2 sorties étant la même pour tous les produits énumérés auparavant.

**ACHTUNG:** Die Darstellung für die Installation der thermostatischen Mischbatterie stützt sich nur auf den Artikel mit 2 Ausgängen, da diese für alle zuvor aufgeführten Produkte gleich ist.

**CAUIDADO:** la representación de la instalación del mezclador termostático se basa en la referencia de 2 salidas, con ser ésta la misma para todos los productos anteriormente mencionados.

**ВНИМАНИЕ:** изображение установки термостатического смесителя было основано только на артикуле с 2 выходами, поскольку она одинакова для всех перечисленных выше артикулов.

**ΠΡΟΣΟΧΗ:** η απεικόνιση της εγκατάστασης της θερμοστατικής αναμικτικής μπαταρίας βασίσθηκε μόνο στο προϊόν με 2 εξόδους καθώς είναι η ίδια για όλα τα προϊόντα που έχουν αναφερθεί προηγουμένως.

**注意:** 因为以前产品都采用同样方式，恒温混水器安装演示仅采用双出口产品。

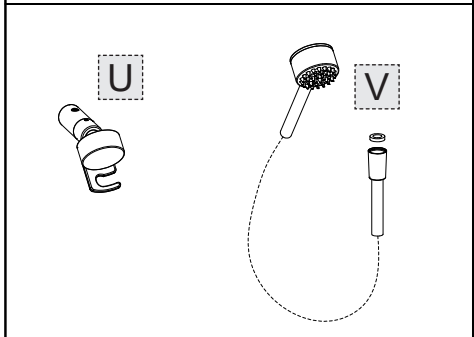
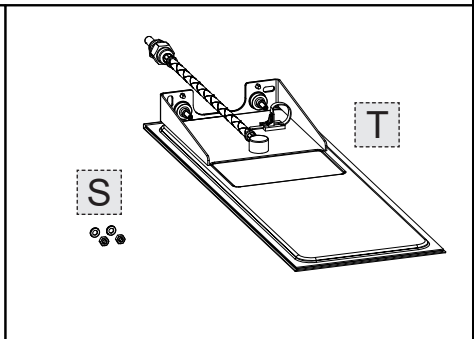
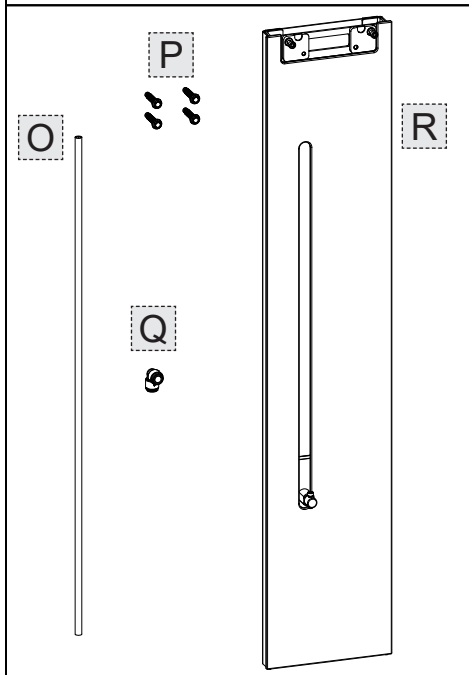
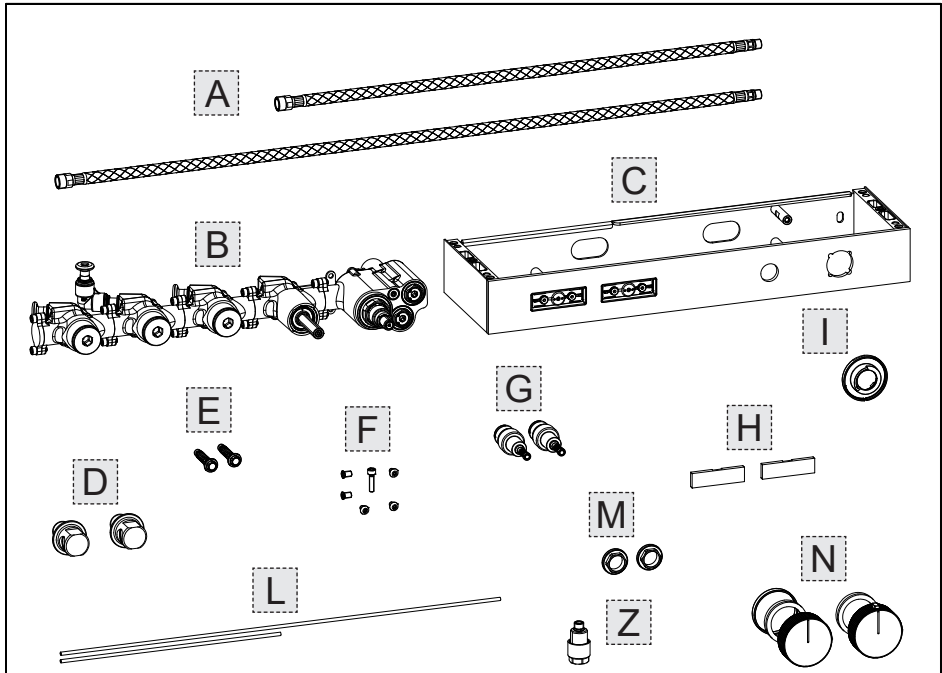

**Contenuto della confezione:**

A - Flessibili di alimentazione  
B - Corpo miscelatore  
C - Carter di finitura  
D - Raccordi a parete  
E - Tasselli di fissaggio  
F - Viti di fissaggio  
G - Deviatore a pulsante  
H - Placca pulsante  
I - Fermo di regolazione della temperatura  
L - Guarnizione  
M - Ghiera di serraggio deviatore a pulsante  
N - Maniglie di comando  
O - Tubo di alimentazione  
P - Tasselli di fissaggio  
Q - Raccordo per tubo di alimentazione  
R - Carter superiore  
S - Set per fissaggio soffione  
T - Soffione  
U - Supporto doccia  
V - Doccetta  
Z - Raccordo G1/2"

**Package content:**

A - Supply hoses  
B - Mixer body  
C - Finish guard  
D - Wall-mounted connections  
E - Fastening plugs  
F - Tightening screws  
G - Pushbutton diverter  
H - Plate with button  
I - Temperature adjustment stop  
L - Gasket  
M - Clamping collar for pushbutton diverter  
N - Control handles  
O - Supply pipe  
P - Fastening plugs  
Q - Connection for feeding pipe  
R - Top guard  
S - Set for shower head fastening  
T - Shower head  
U - Hand shower support  
V - Handshower  
Z - Link G1/2"

**Contenu de l'emballage:**

A - Flexible d'alimentation  
B - Corps mélangeur  
C - Carter de finition  
D - Raccords à paroi  
E - Fiches de fixation  
F - Vis de fixation  
G - Inverseur à bouton-poussoir  
H - Plaque avec bouton-poussoir  
I - Arrêts de réglage de la température  
L - Gaine  
M - Bague de serrage pour inverseur à bouton-poussoir  
N - Poignée de commande  
O - Tuyau d'alimentation  
P - Fiches de fixation  
Q - Connexion pour tuyau d'alimentation  
R - Carter supérieur  
S - Set fixation pomme de douche  
T - Pomme  
U - Support douchette  
V - Douchette  
Z - Connexion G1/2"

**Inhalt der Verpackung:**

A - Flexanschlußschlauch  
B - Mischerkörper  
C - Endgehäuse  
D - Wandanschlüsse  
E - Befestigungsdübel  
F - Befestigungsschrauben  
G - Druckknopfumstellventil  
H - Druckknopfplakette  
I - Feststellvorrichtung für die Temperatureinstellung  
L - Dichtung  
M - Gewindehülse zum Festziehen vom Druckknopfumstellventil  
N - Steuergriffe  
O - Versorgungsleitung  
Q - Befestigungsdübel  
R - Befestigungsdübel für Versorgungsrohr  
S - Oberes Gehäuse  
T - Feststellungsbauszatz für den Brausekopf  
U - Halterung der Handbrause  
V - Handbrause  
Z - Verbindungsstutzen G1/2"

**Contenido de la caja:**

A - Flexibles de alimentación  
B - Cuerpo del mezclador  
C - Carter de acabado  
D - Racores de pared  
E - Tacos de fijación  
F - Tornillos de fijación  
G - Desviador de botón  
H - Placa botón  
I - Retén de regulación de la temperatura  
L - Junta  
M - Virola de cierre desviador de botón  
N - Manetas de mando  
O - Tubo de alimentación  
P - Tacos de fijación  
Q - Unión para tubo de alimentación  
R - Carter superior  
S - Juego de fijación para rociador  
T - Rociador  
U - Soporte ducha-teléfono  
V - Ducha-teléfono  
Z - Conexión G1/2"

**Содержимое упаковки:**

A - Питательный шланг  
B - Корпус смесителя  
C - Декоративный кожух  
D - Стенные фитинги  
E - Крепежные дюбели  
F - Установочные винты  
G - Кнопочный переключатель  
H - Плита с кнопкой  
I - Регулировочный стопор температуры  
L - Уплотнение  
M - Зажимное кольцо для кнопочного переключателя  
N - Ручки управления  
O - Водопроводная труба  
P - Крепежные дюбели  
Q - Соединение для питательной трубы  
R - Верхний кожух  
S - Установочный набор для душевой головы  
T - Душевая лейка  
U - Держателя душа  
V - Душ  
Z - Штуцер 1/2"

**Περιεχόμενο συσκευασίας:**

A - Σωλήνες τροφοδοσίας  
B - Σώμα μπαταρίας αναμίκτη  
C - Κάρτερ φινιρίσματος  
D - Επιτοίχια ρακόρ  
E - Τάκοι στερέωσης  
F - Βίδες στερέωσης  
G - Εκτροπέας με πλήκτρο  
H - Πλάκα πλήκτρου  
I - Στοιπ ρύθμισης της θερμοκρασίας  
L - Παρέμβυσμα  
M - Δακτύλιο σύσφιξης εκτροπέα με πλήκτρο  
N - Λαβές εντολής  
O - Σωλήνας τροφοδοσίας  
P - Τάκοι στερέωσης  
Q - Ρακόρ σωλήνα τροφοδοσίας  
R - Άνω κάρτερ  
S - Σετ στερέωσης φυσητήρα  
T - Φυσητήρας  
U - Βάση για ντουςάκι  
V - Ντουςάκι  
Z - Ρακόρ G1/2"

**包裝內容:**

A - 进水软管  
B - 混水器机体  
C - 装饰护罩  
D - 墙内管接  
E - 固定楔  
F - 固定螺钉  
G - 换向按钮  
H - 按钮面板  
I - 温度调节手柄锁止器  
L - 垫圈  
M - 换向按钮锁定环  
N - 控制手柄  
O - 供水管  
P - 固定楔  
Q - 进水管接  
R - 顶部护板  
S - 喷淋器固定用套件  
T - 喷淋器  
U - 手持花洒支架  
V - 手持花洒  
Z - G1/2" 接头

Fig. 1

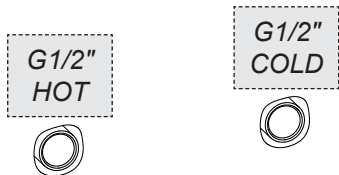

Fig. 3

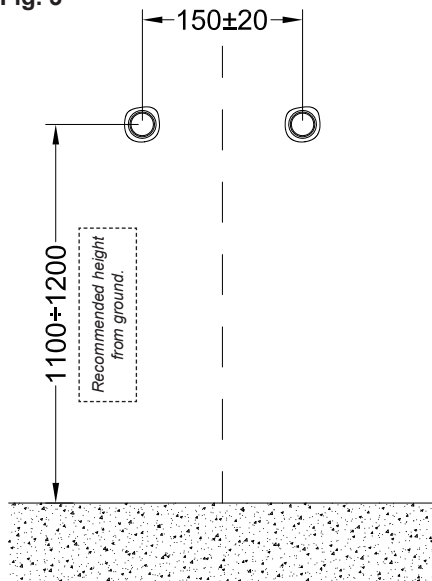

Fig. 2

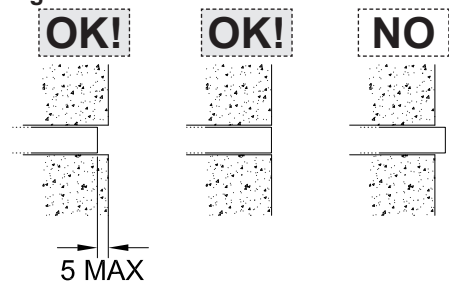

Fig. 4

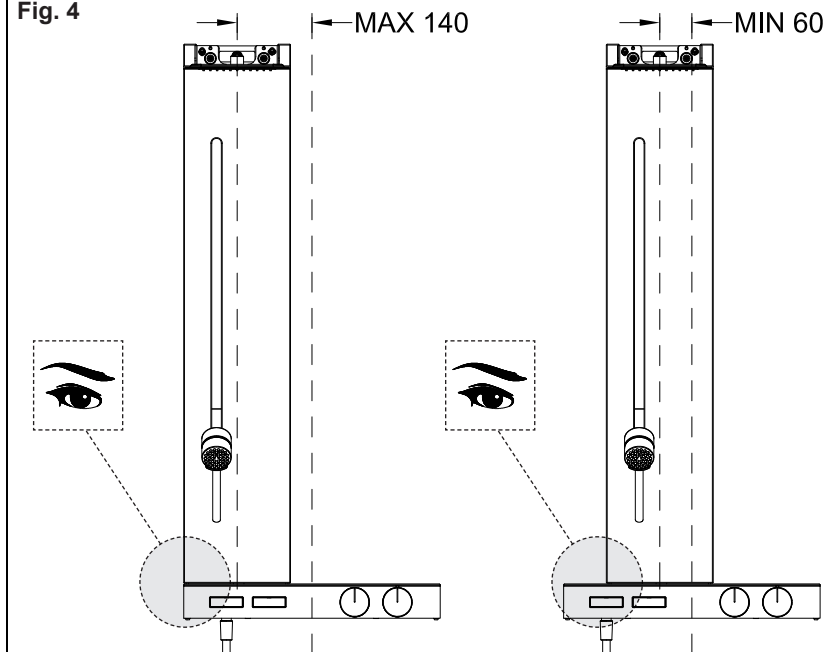

Fig. 5

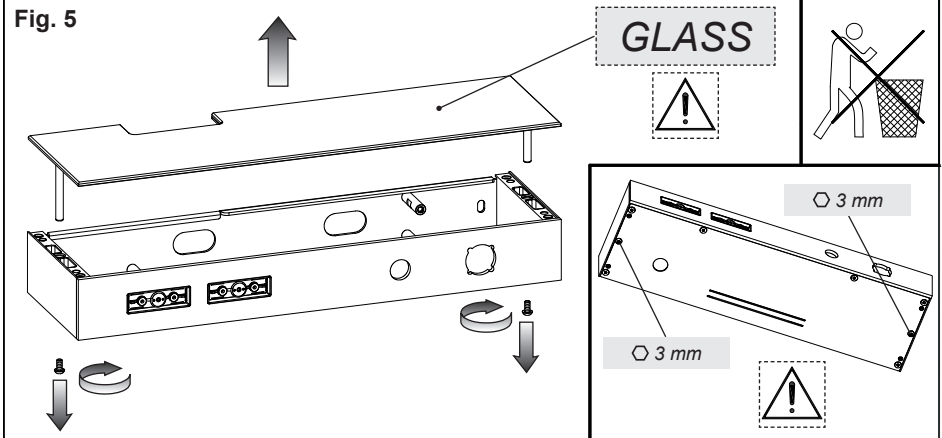

Fig. 6

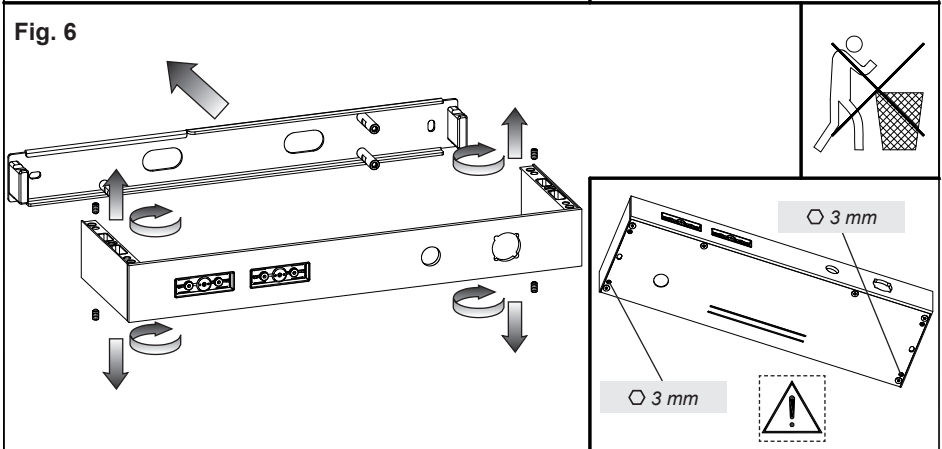

Fig. 7

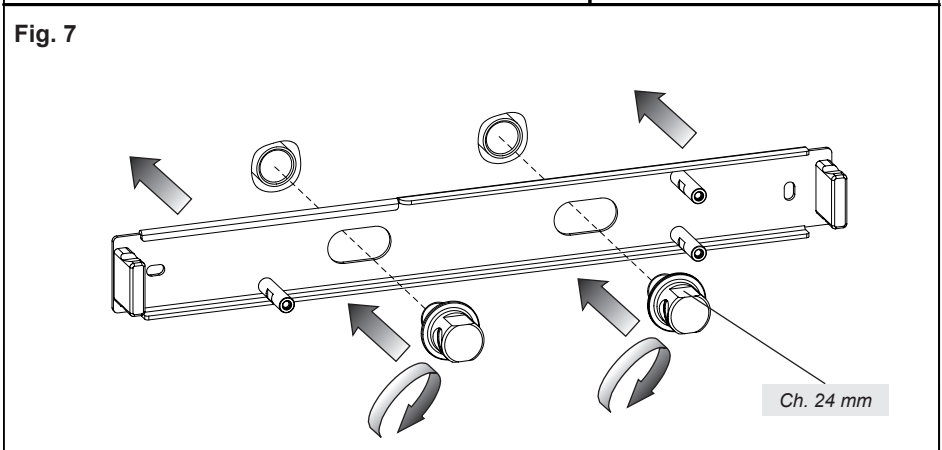

Fig. 8

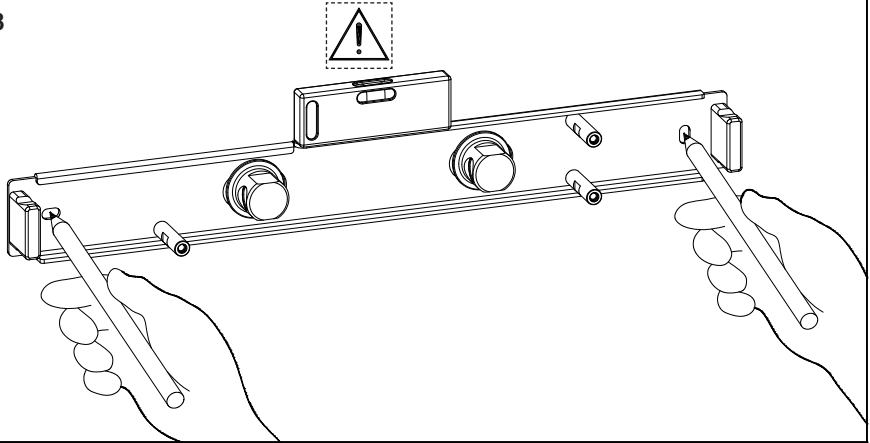

Fig. 9

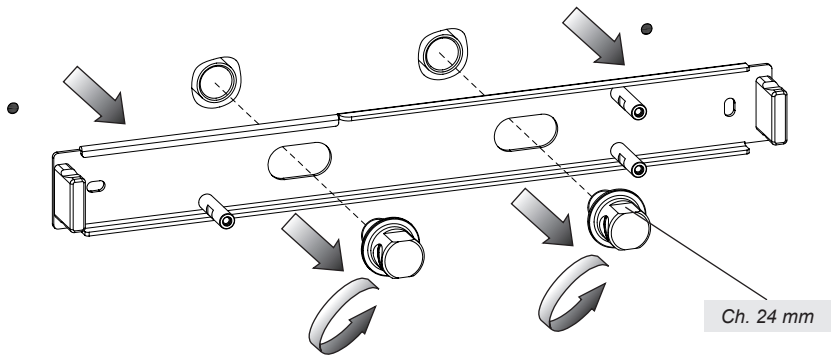

Fig. 10

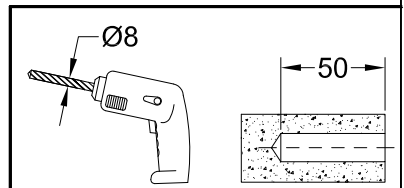
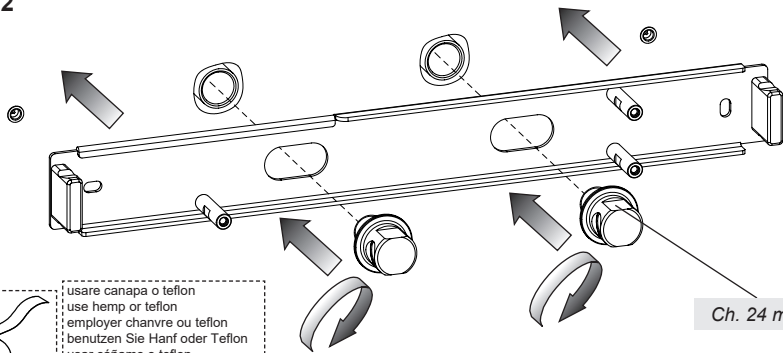

Fig. 11



Fig. 12



usare cânăpa o teflon  
 use hemp or teflon  
 employer chanvre ou teflon  
 benutzen Sie Hanf oder Teflon  
 usar cânăpa o teflon  
 использовать лен или тефлон  
 χρησιμοποιήστε κάνναβι ή τeflon  
 使用麻丝或特氟龙

Ch. 24 mm

**RIGHT INSTALLATION**

**WRONG INSTALLATION**

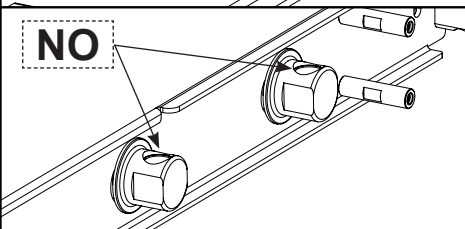
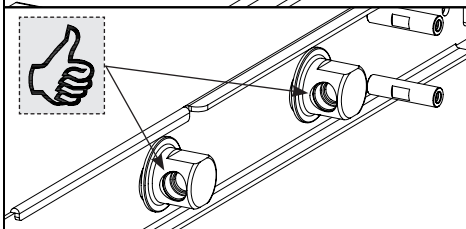
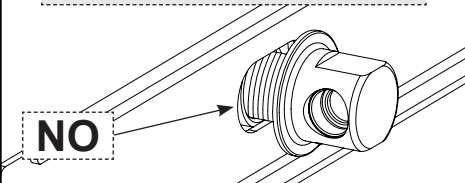
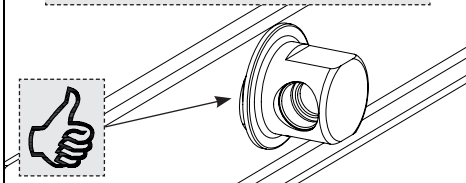

Fig. 13

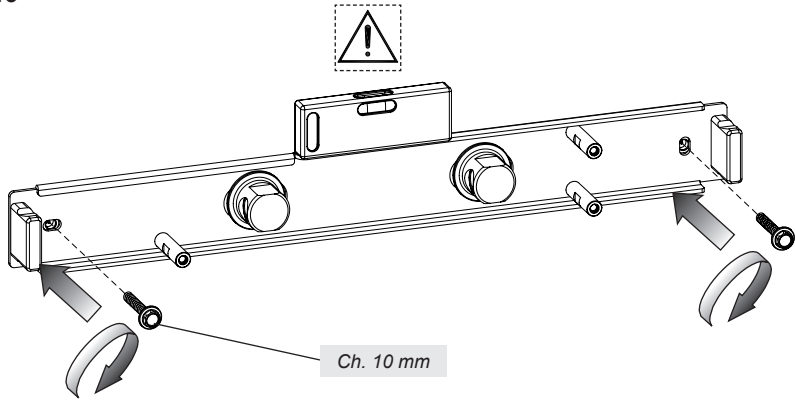

Fig. 14

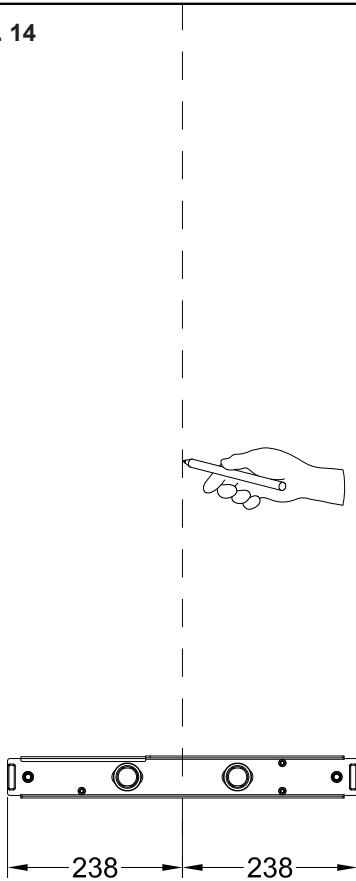
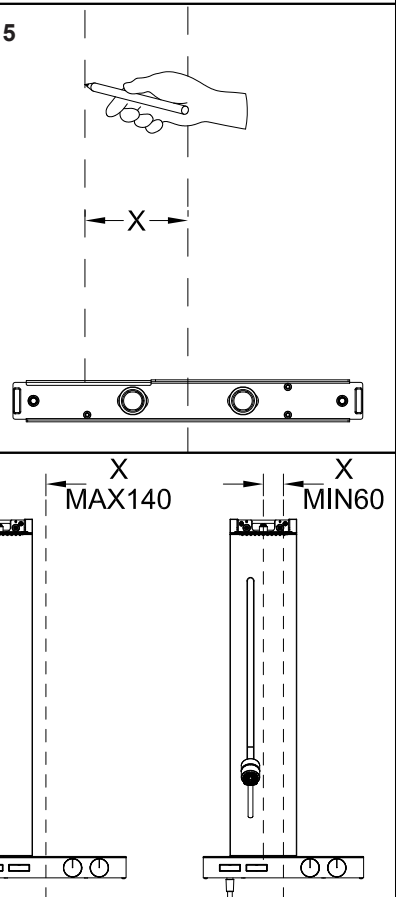
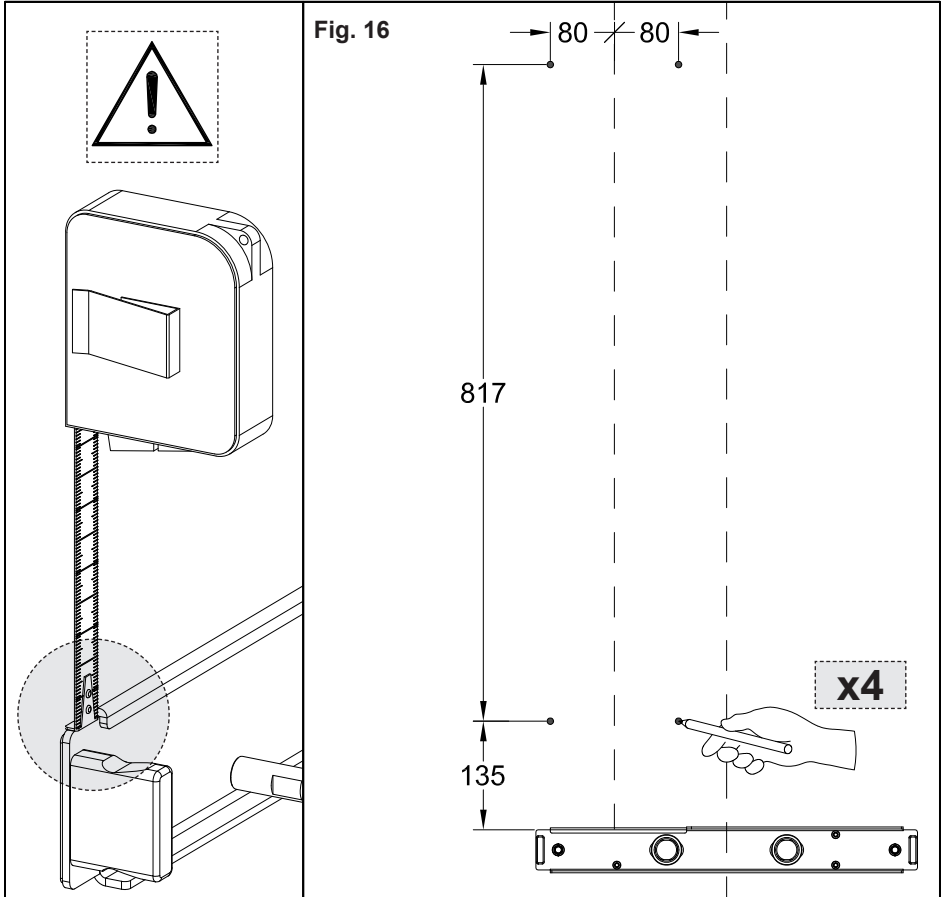

Fig. 15





**Fig. 17**

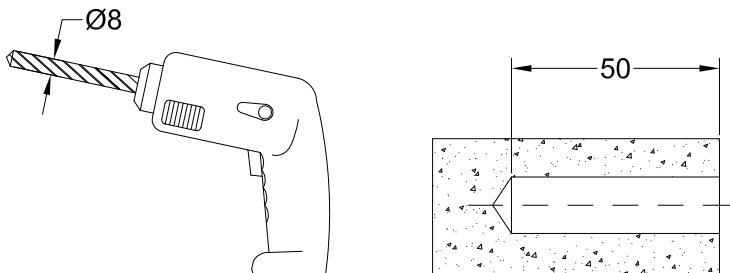

Fig. 18

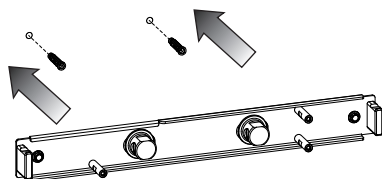
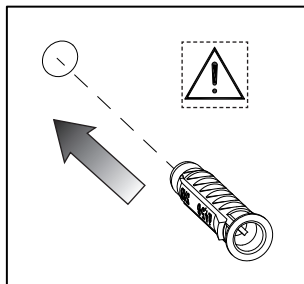
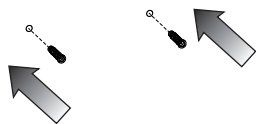

Fig. 19

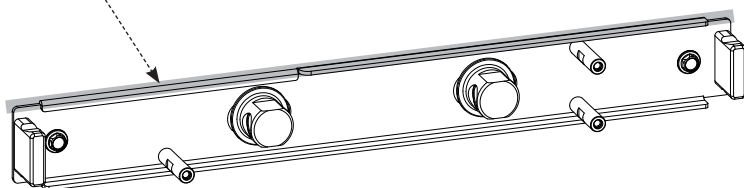
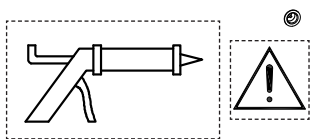

Fig. 20

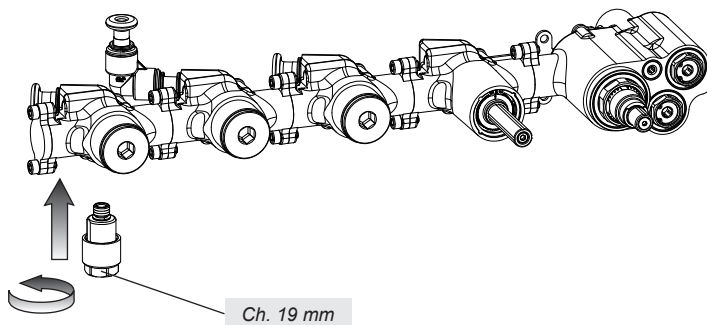

Fig. 21

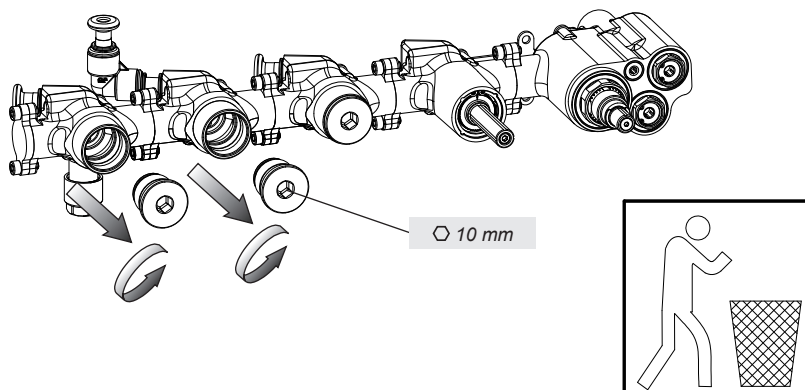

Fig. 22

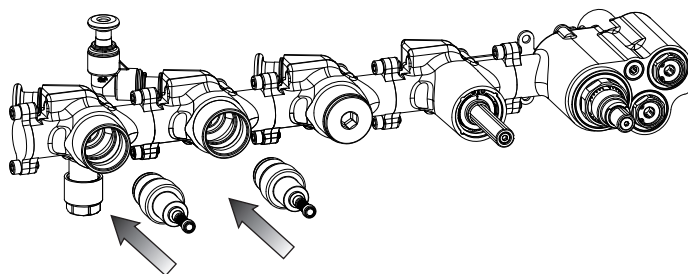

Fig. 23

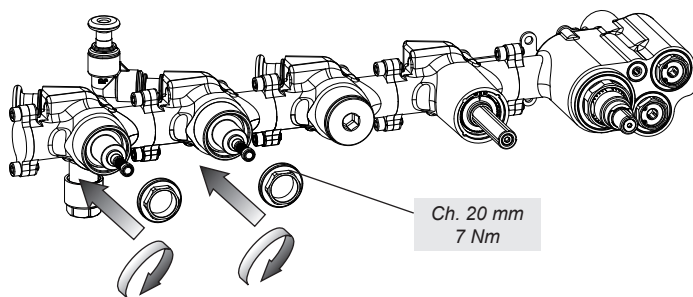

Fig. 24

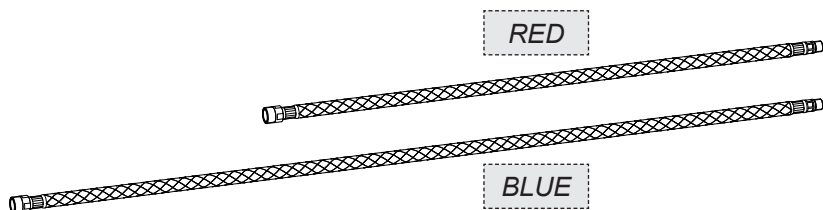

Fig. 25

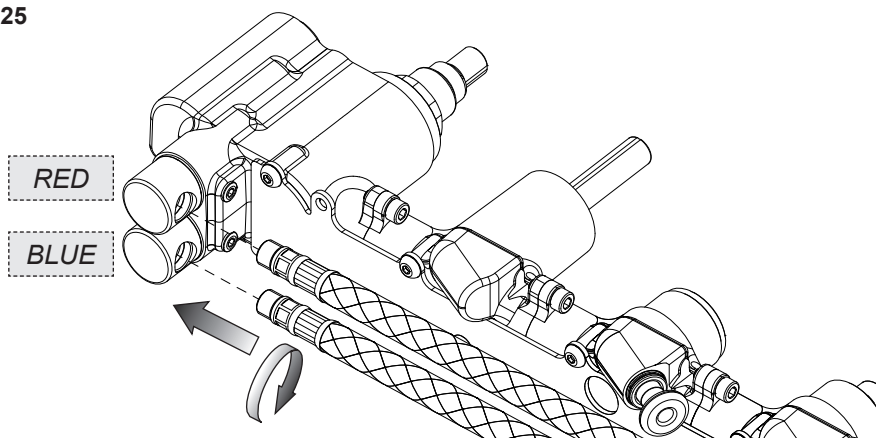

Fig. 26

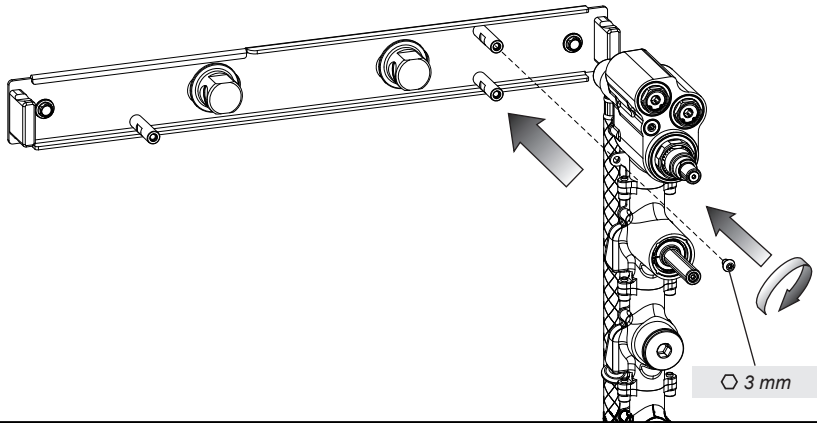

Fig. 27

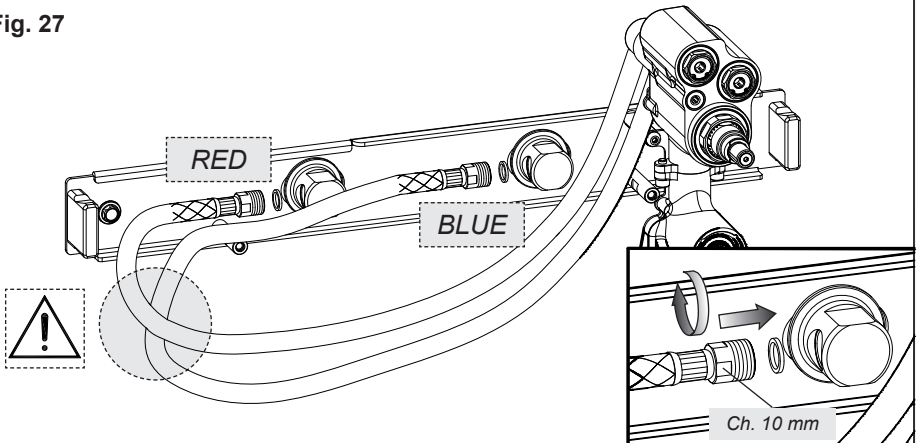

Fig. 28

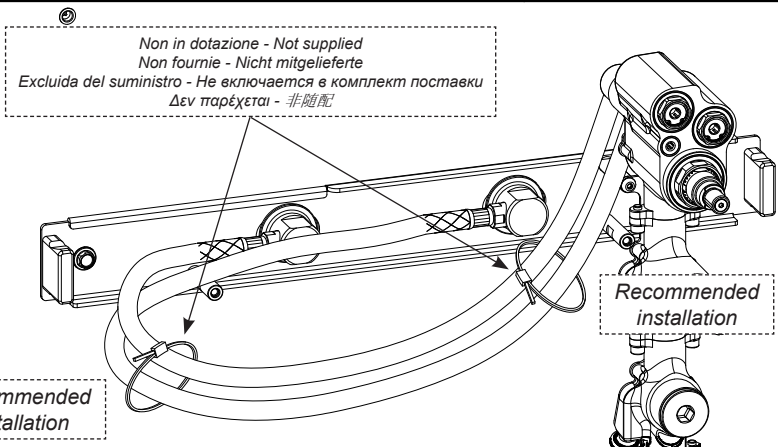

Fig. 29

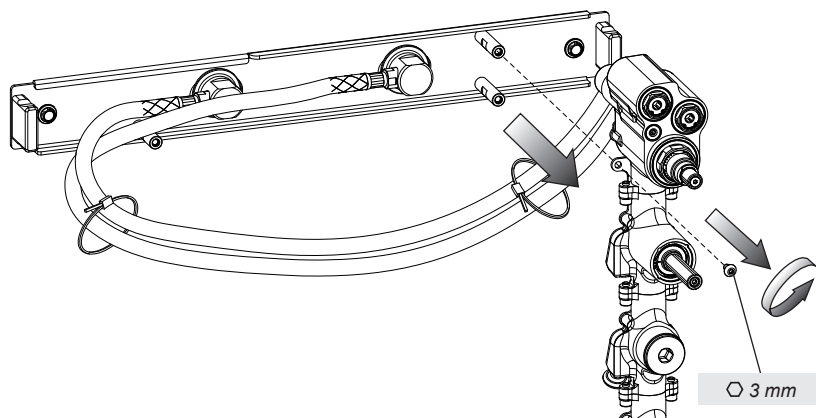

Fig. 30

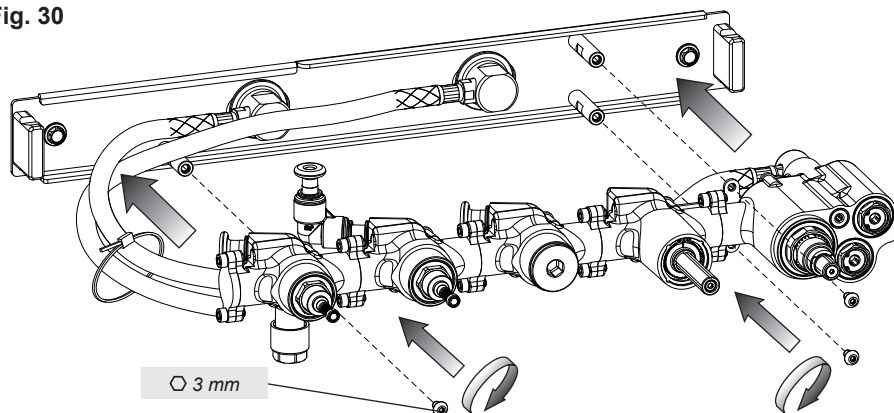

Fig. 31

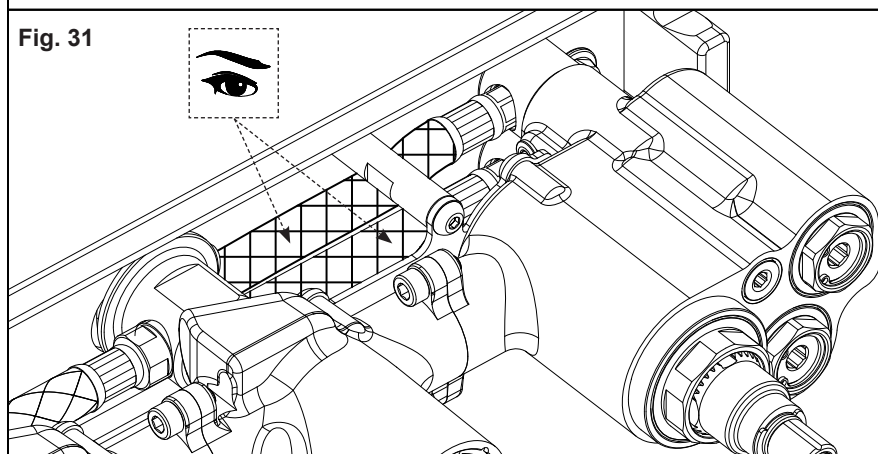

Fig. 32

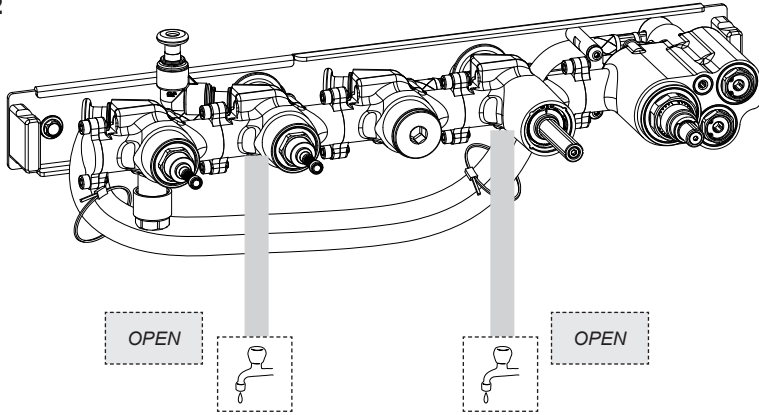

Fig. 33

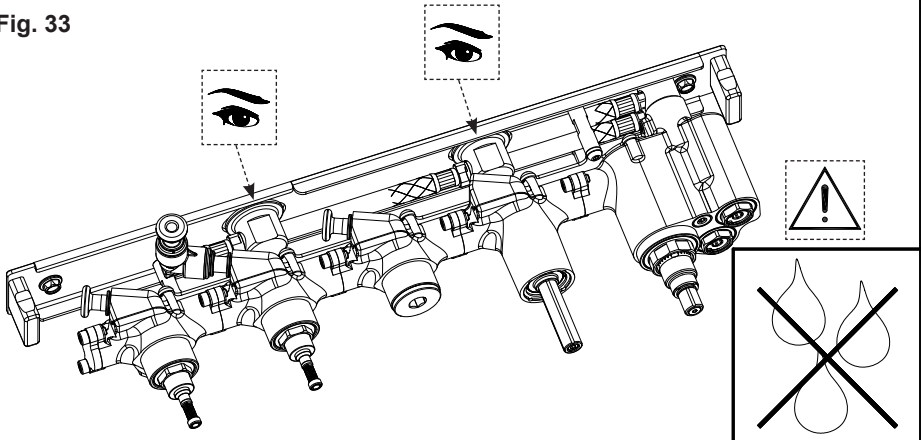

Fig. 34

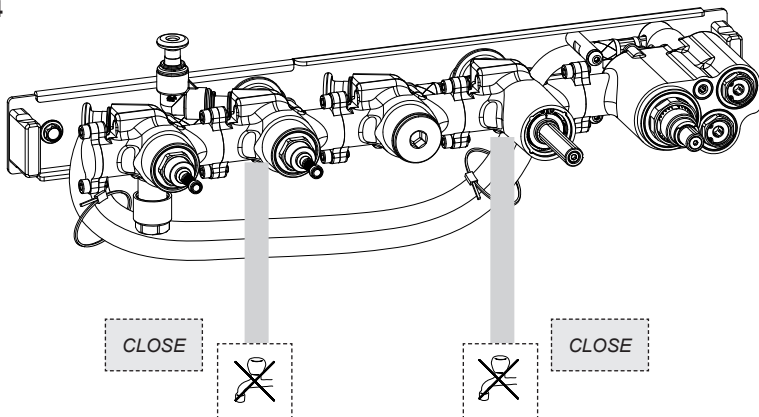

Fig. 32

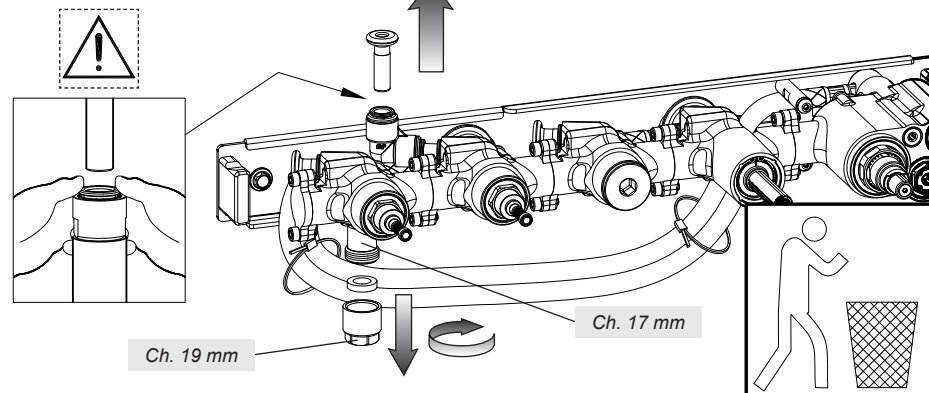

Fig. 33

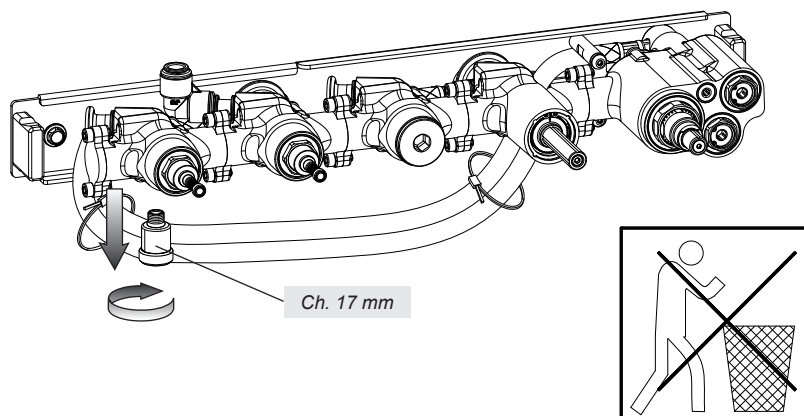

Fig. 34

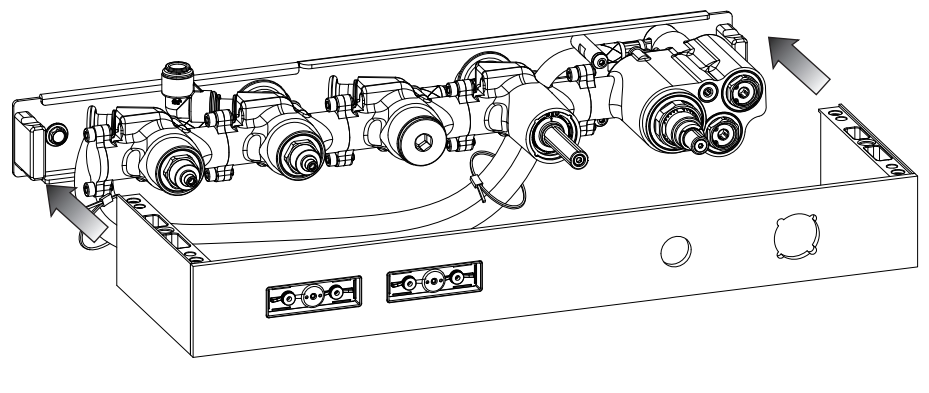

Fig. 35

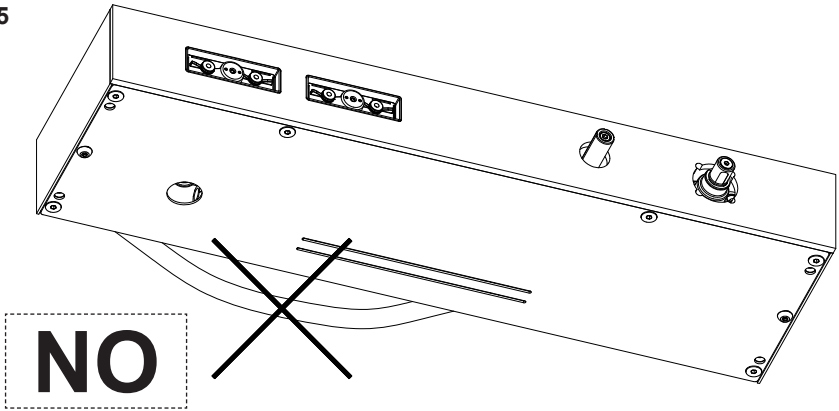

Fig. 36

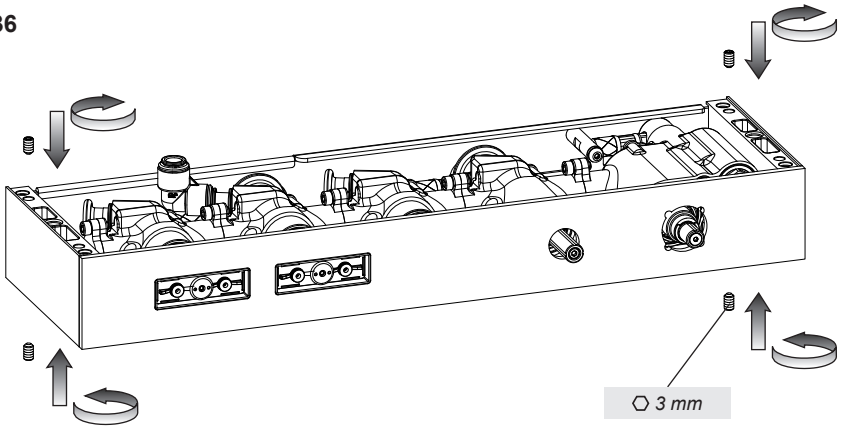

Fig. 37

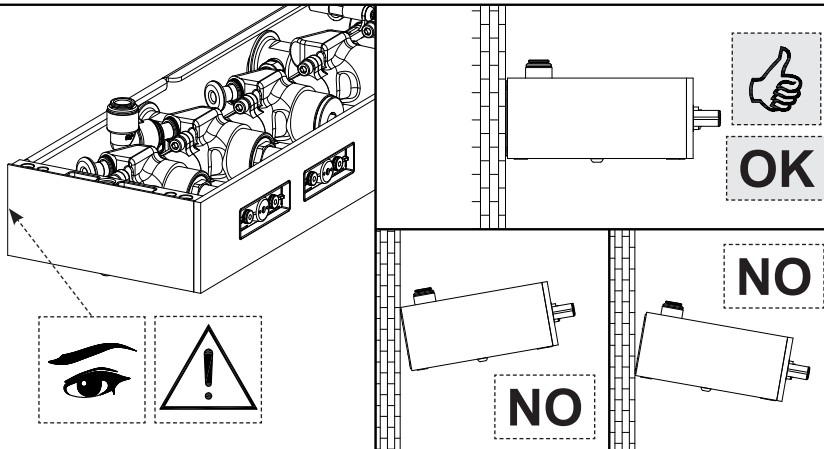

Fig. 38

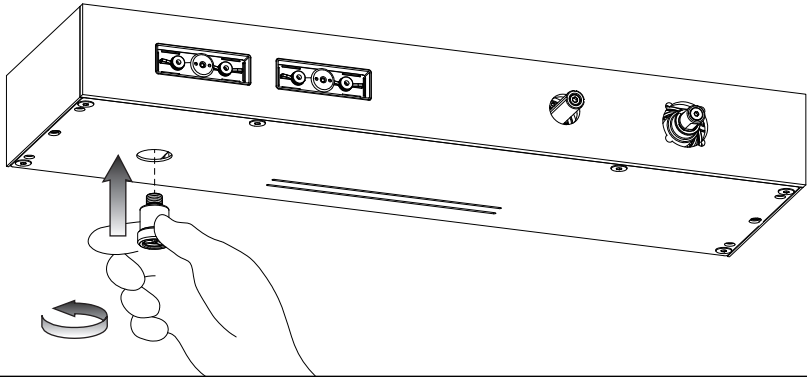

Fig. 39

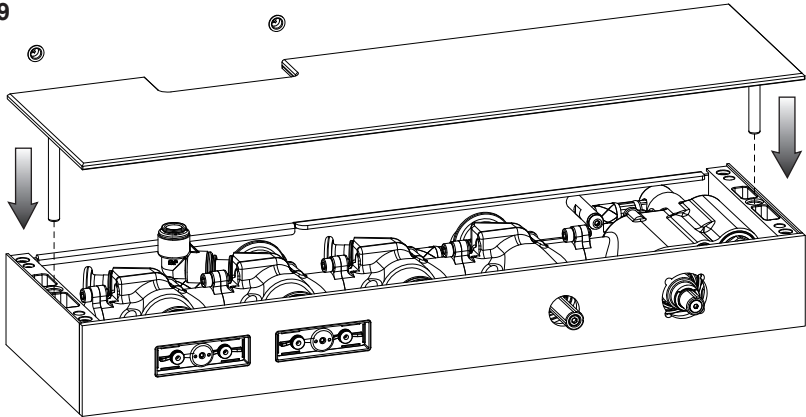

Fig. 40

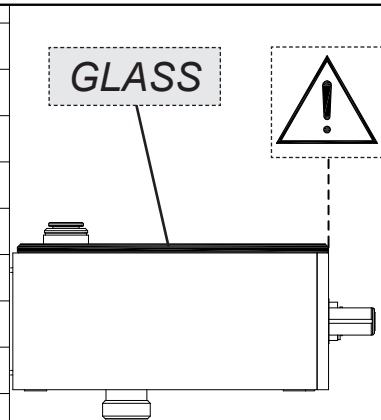
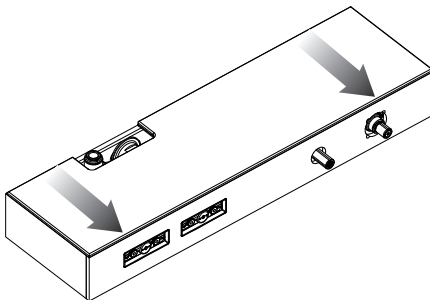

Fig. 41

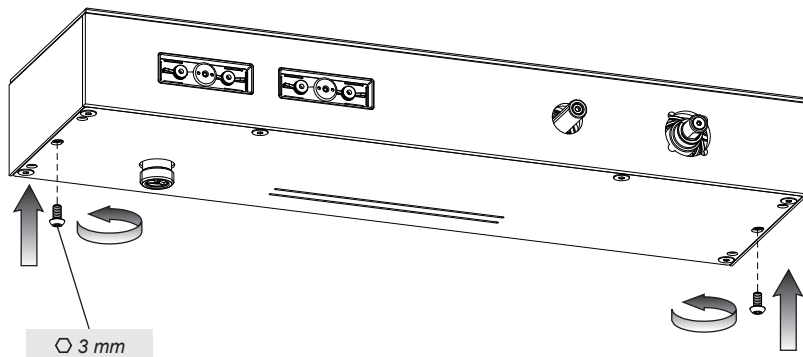

Fig. 42

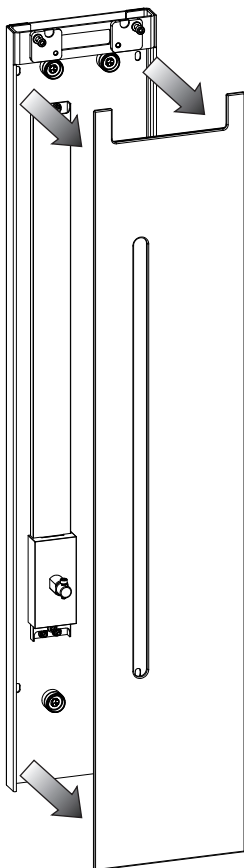

Fig. 43

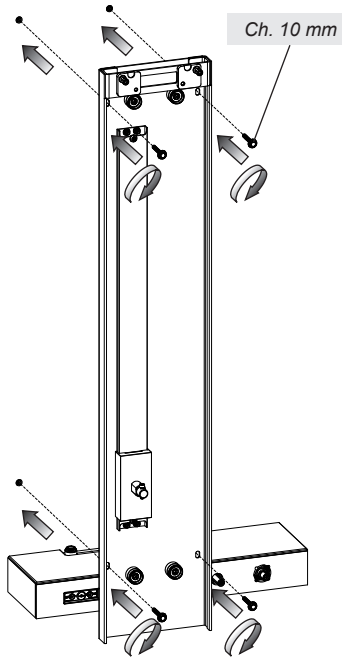

Fig. 44

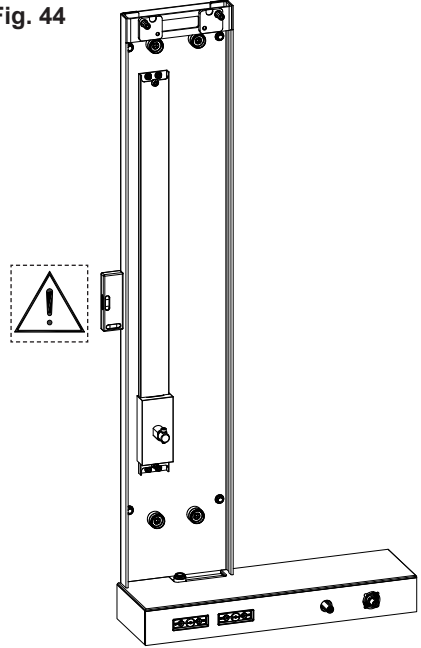

Fig. 45

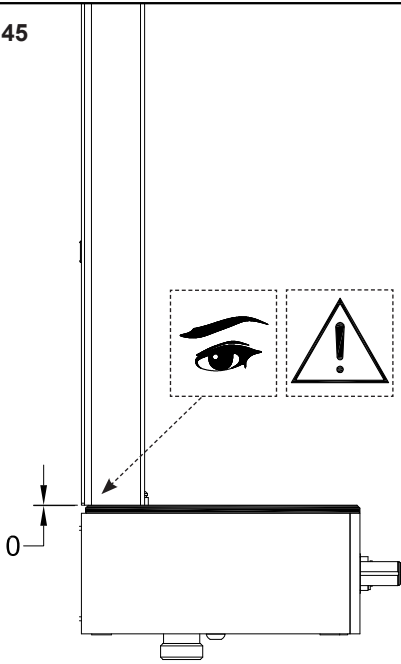

Fig. 46

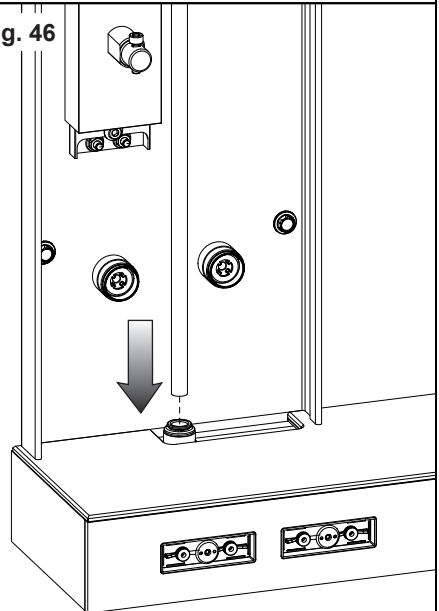

Fig. 47

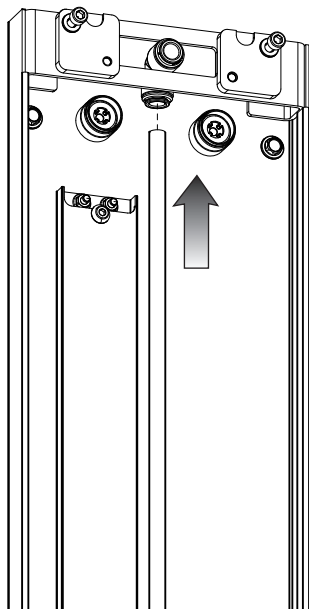

Fig. 48

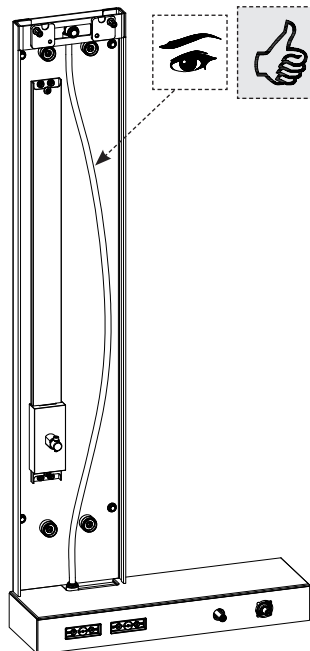

Fig. 49

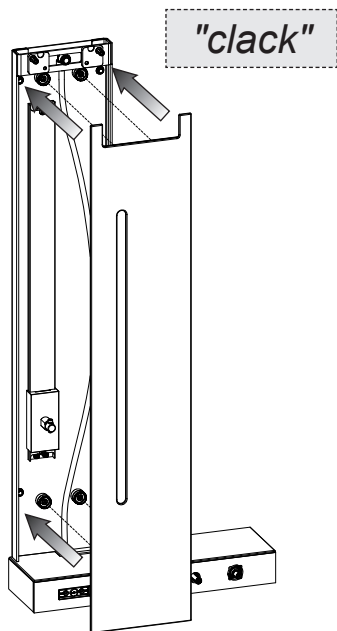

Fig. 50

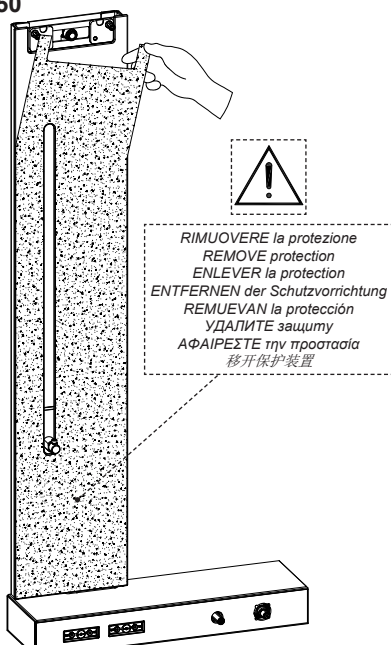

Fig. 51

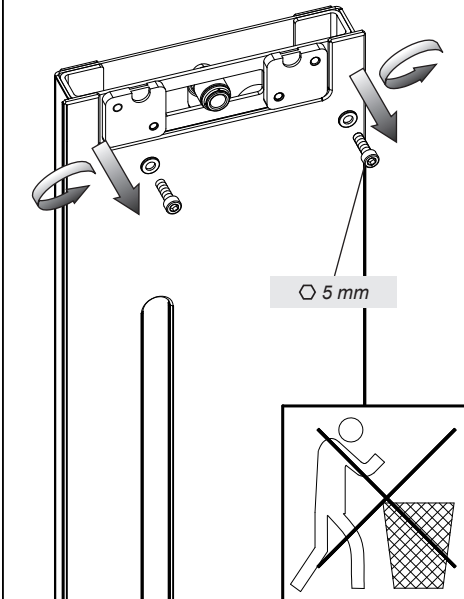

Fig. 52

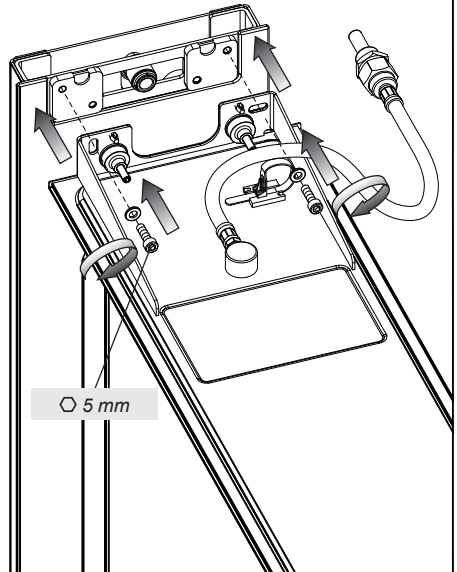

Fig. 53

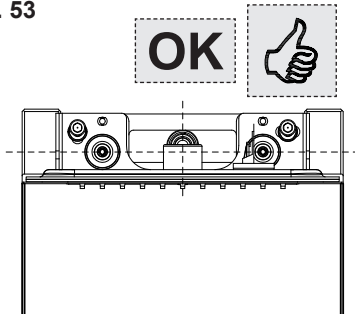

Fig. 54

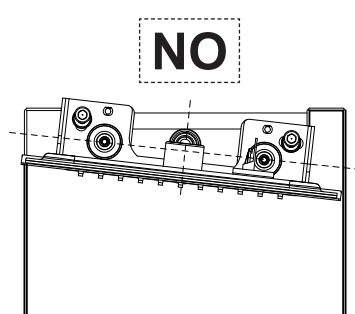

Fig. 55

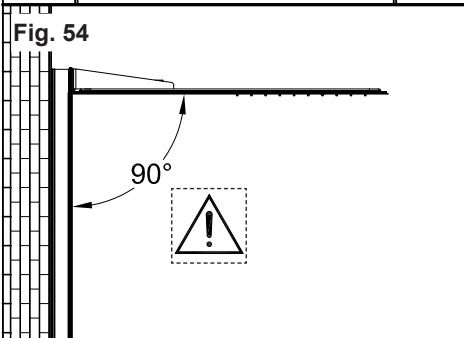

Fig. 56

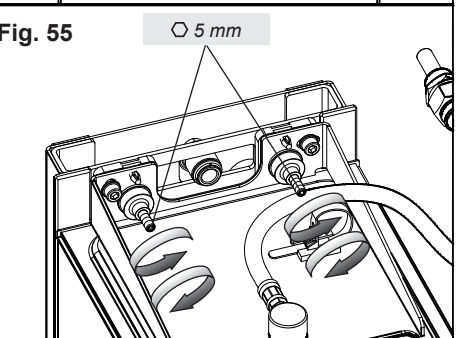

Fig. 56

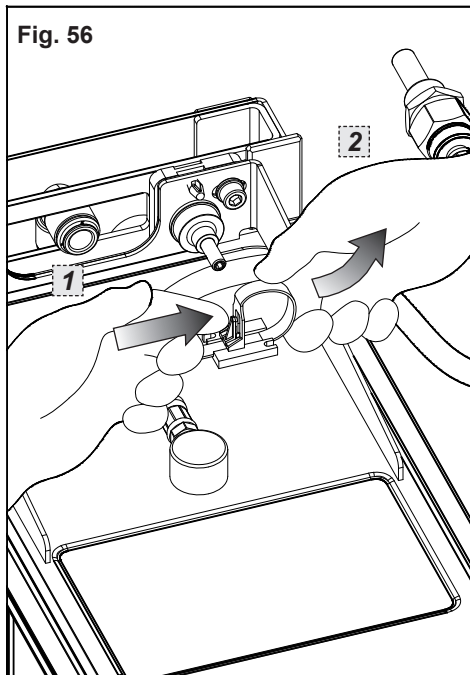

Fig. 57

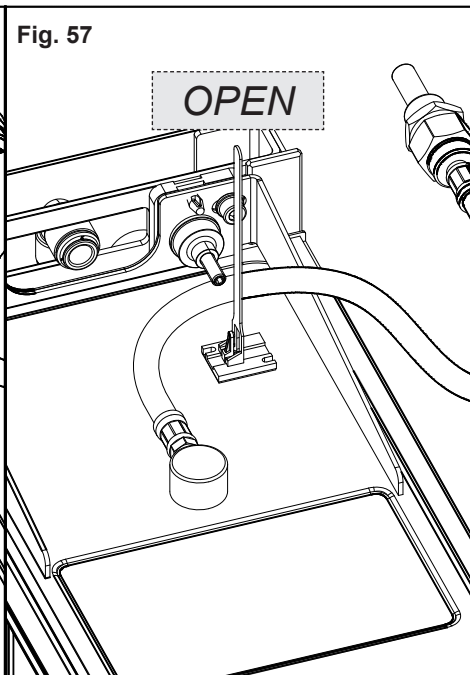

Fig. 58

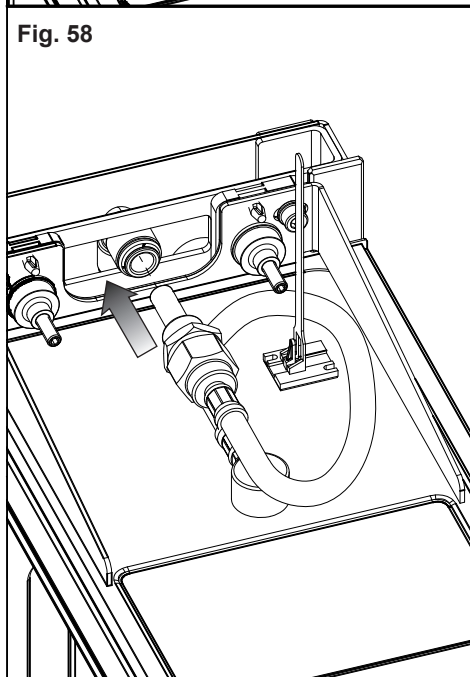

Fig. 59

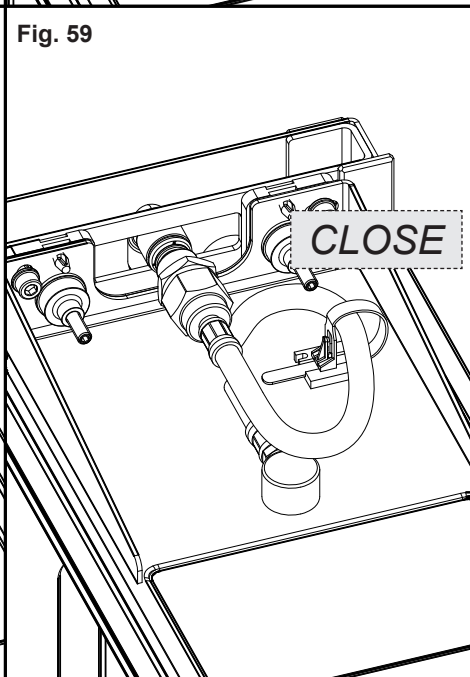

Fig. 60

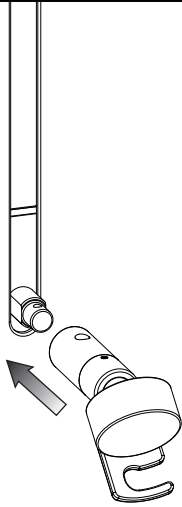

Fig. 61

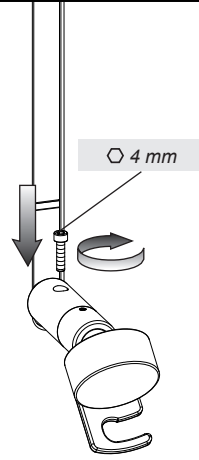
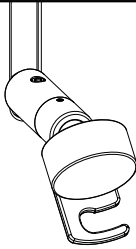

Fig. 62



RIMUOVERE la protezione - REMOVE protection  
ENLEVER la protection - ENTFERNEN der Schutzvorrichtung  
REMUEVAN la protecció - УДАЛИТЕ защиту  
ΑΦΑΙΡΕΣΤΕ την προστασία - 移开保护装置

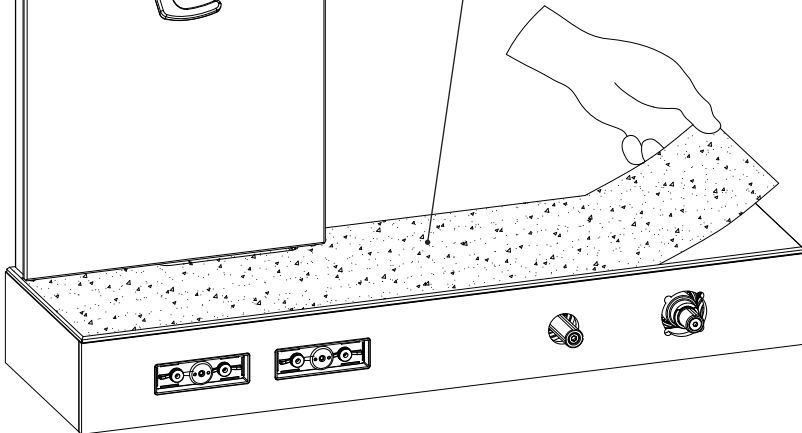

Fig. 63

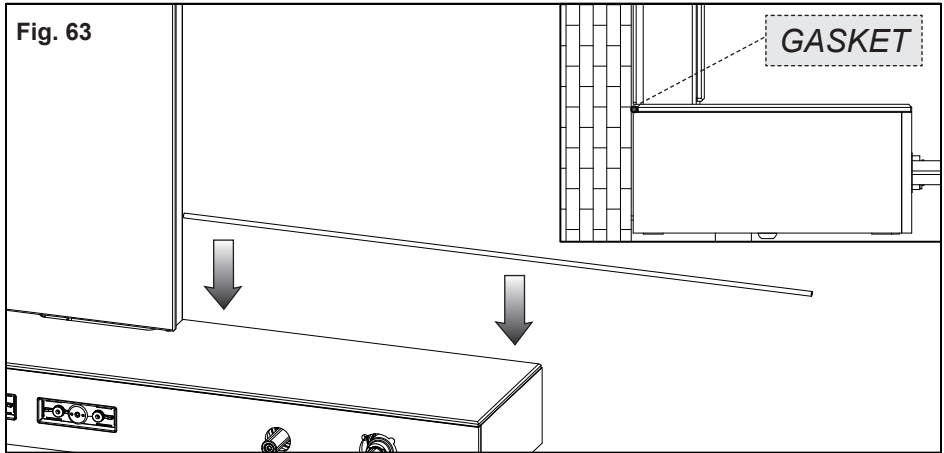

Fig. 64

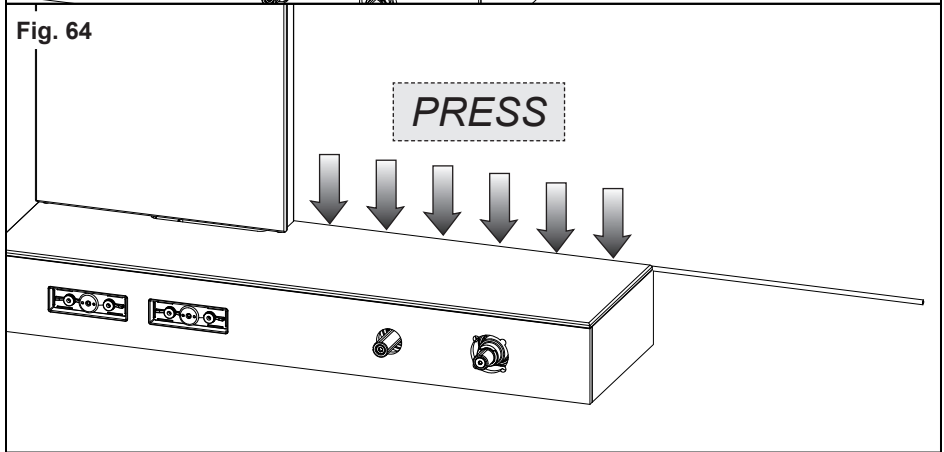

Fig. 65

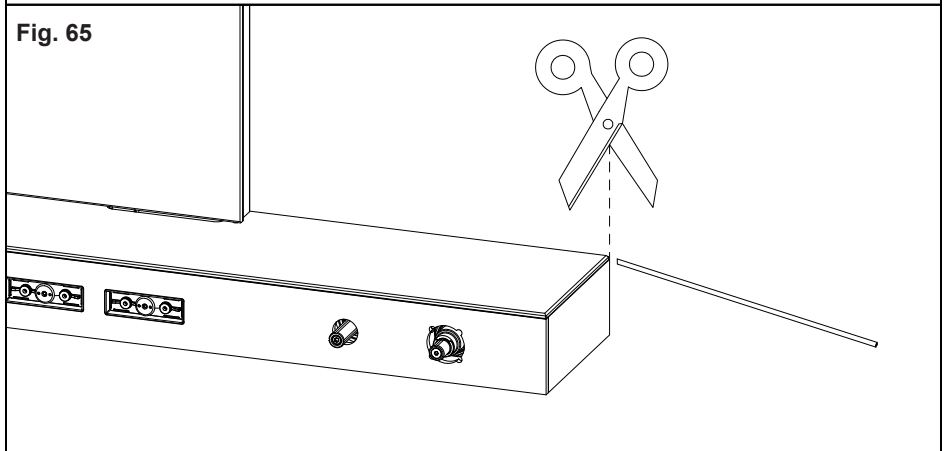

Fig. 66

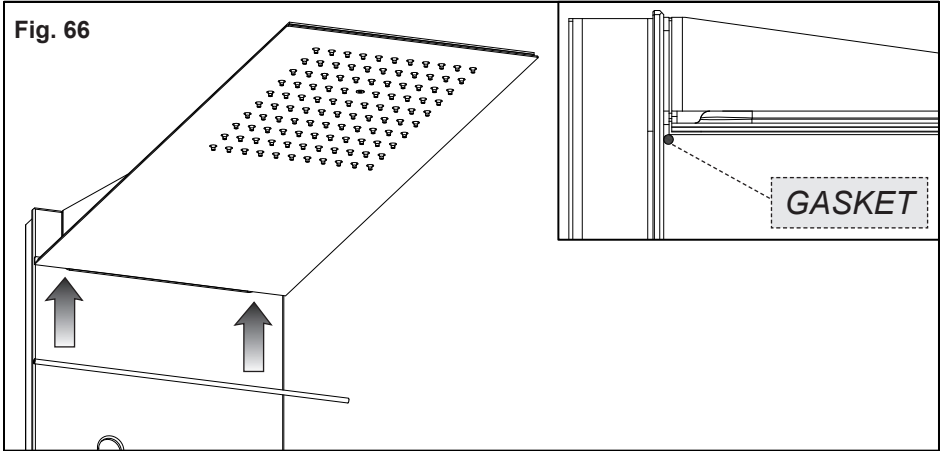

Fig. 67

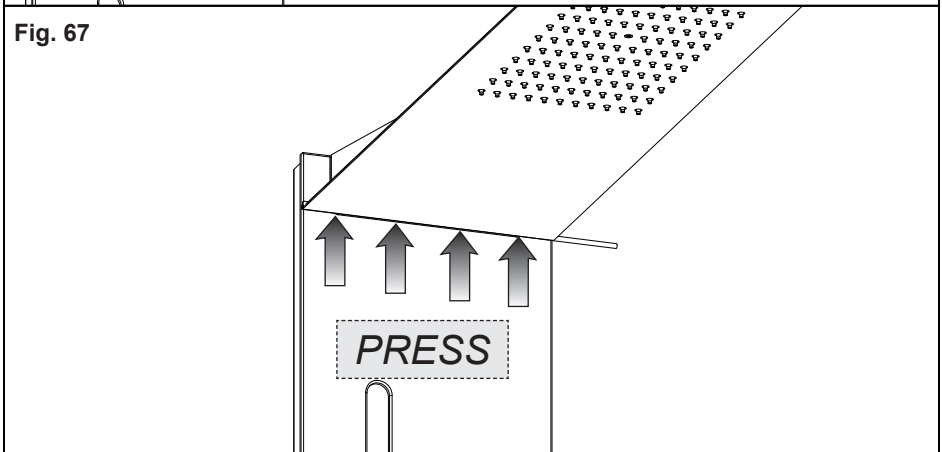

Fig. 68

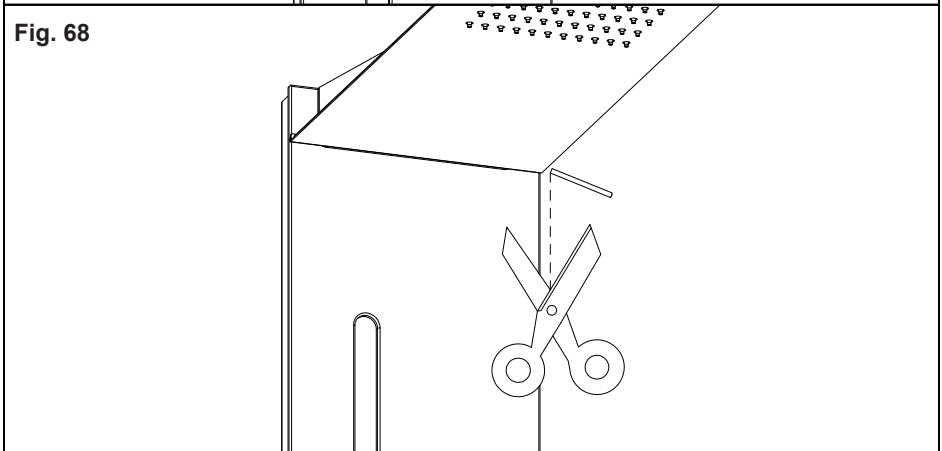

Fig. 69

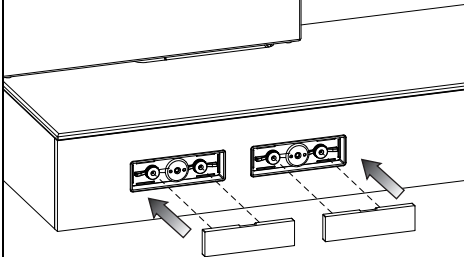
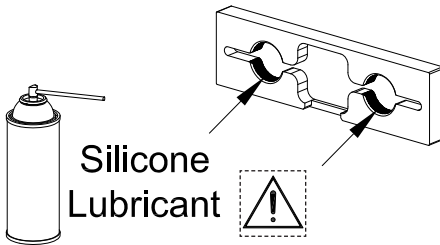
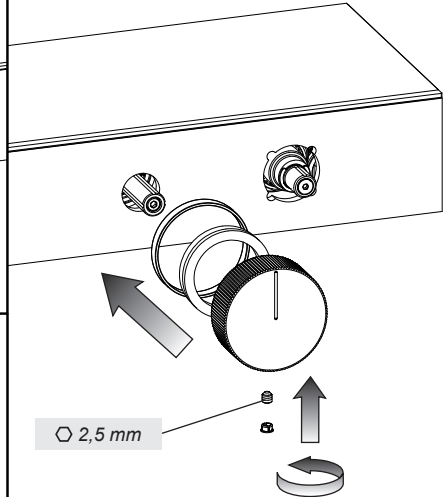

Fig. 70



Silicone  
Lubricant



Fig. 71

*Biadesivo - Biadhesive -  
Doubleadhésif - Beiseitig klebend Streifen -  
Precinto doble cara - Двусторонняя липкая лента -  
δίπλο αυτοκόλλητο - 双面胶*

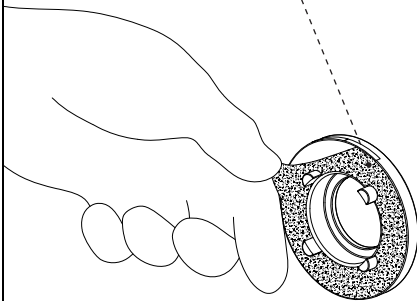

Fig. 72

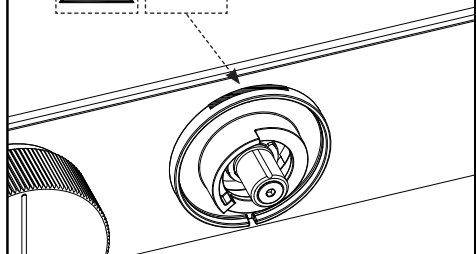
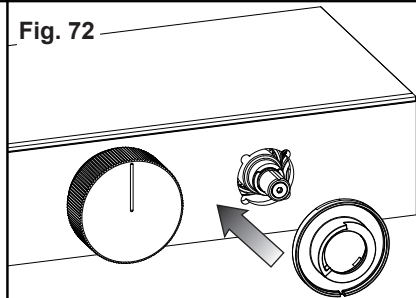

Fig. 73

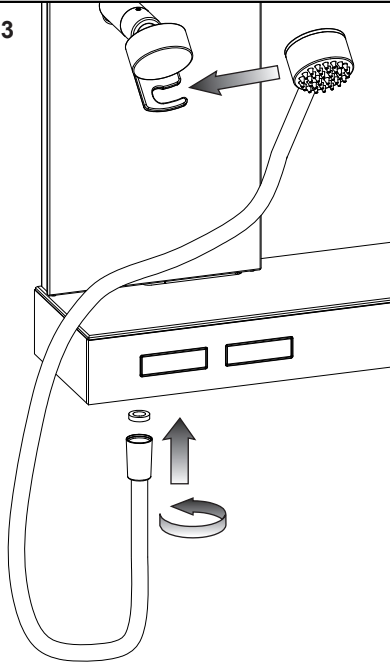

Fig. 74

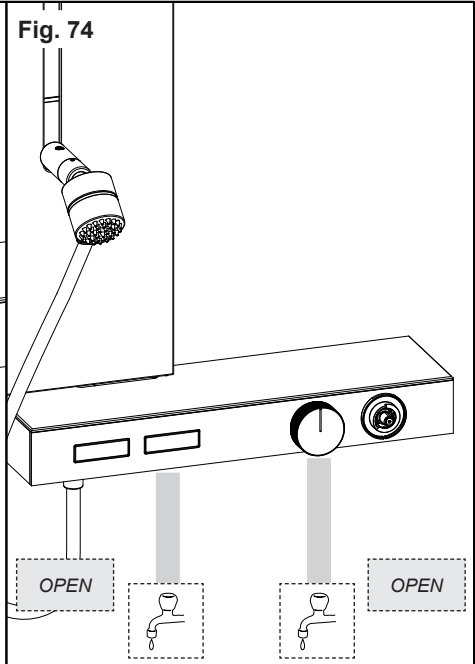

Fig. 75

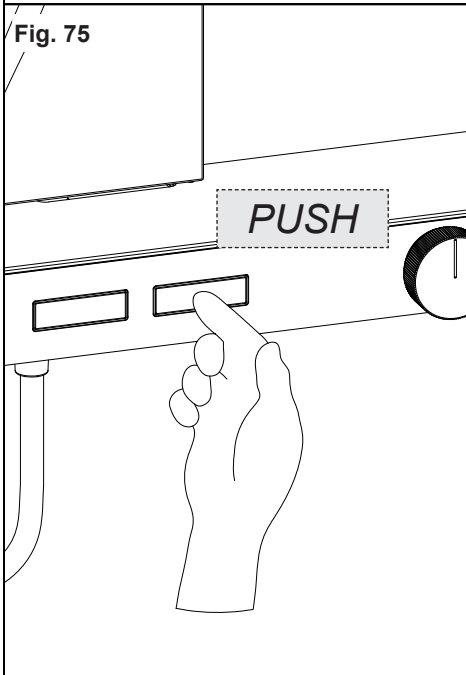

Fig. 76

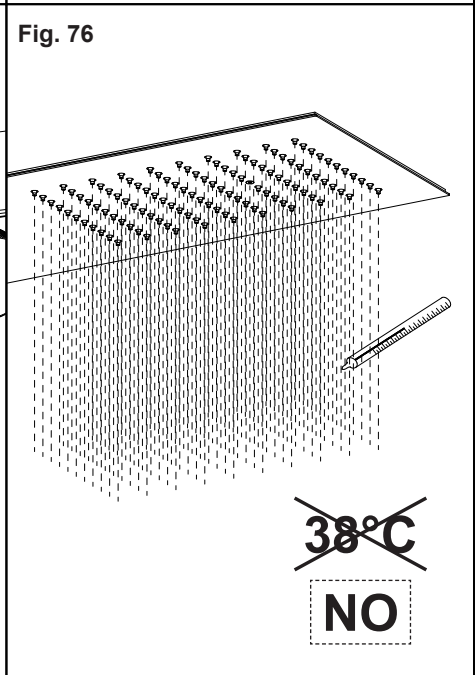

Fig. 77

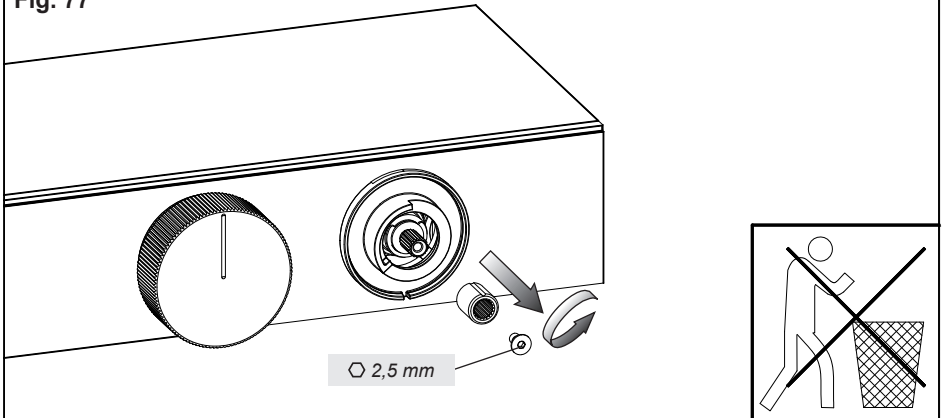

Fig. 78

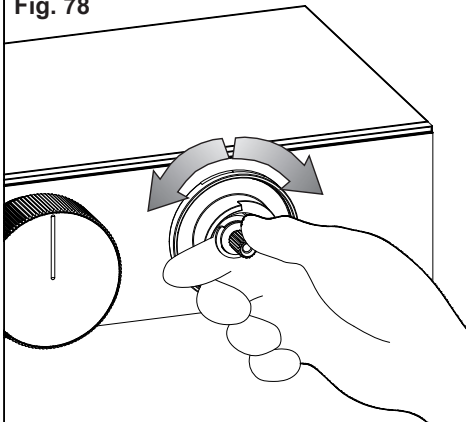

Fig. 79

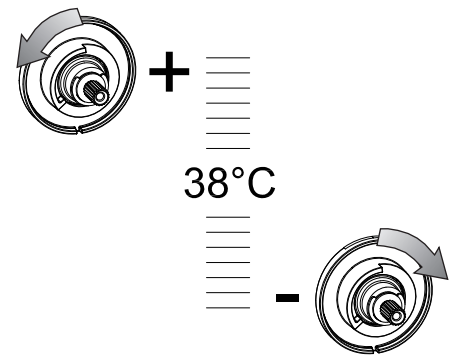

Fig. 80

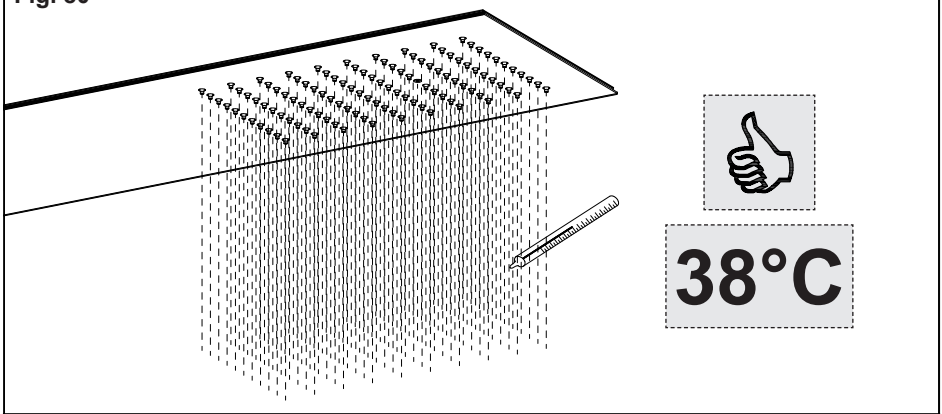

Fig. 81

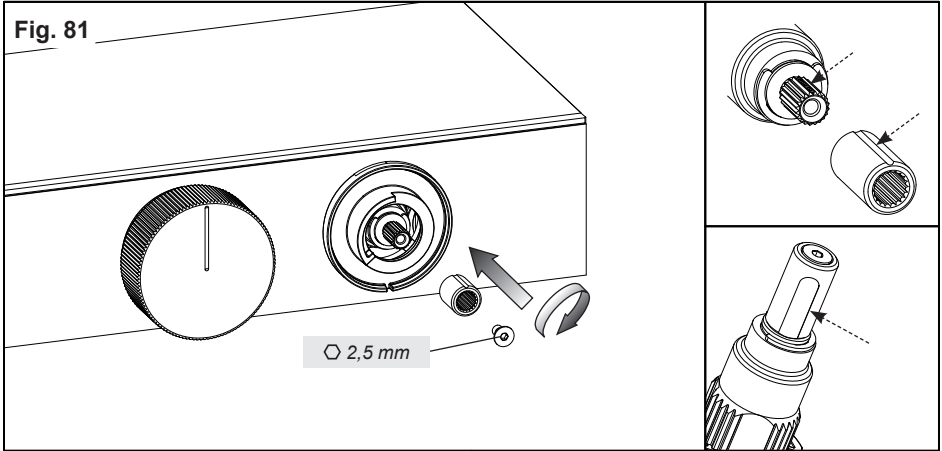

Fig. 82

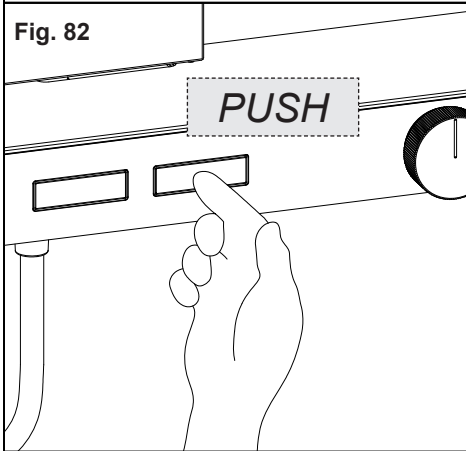

Fig. 83

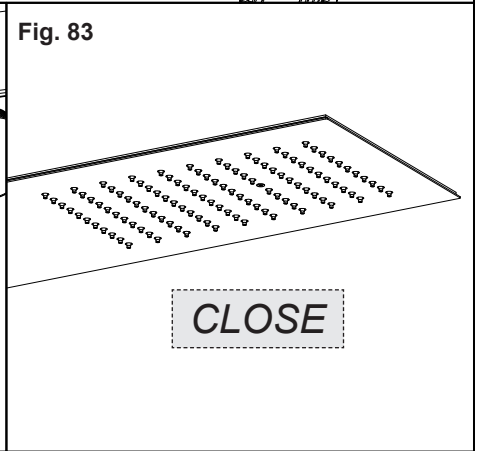

Fig. 84

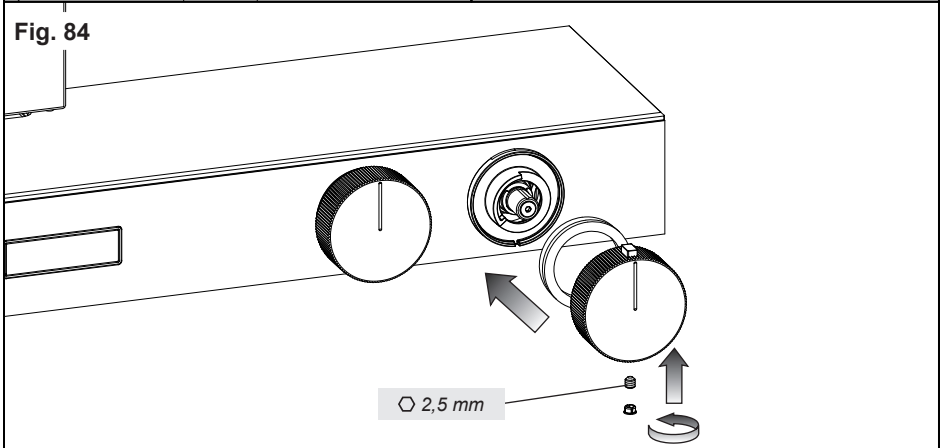
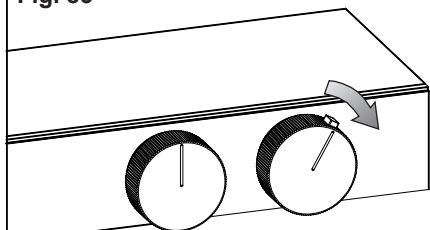

Fig. 85



38°C  
↓  
30°C

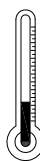
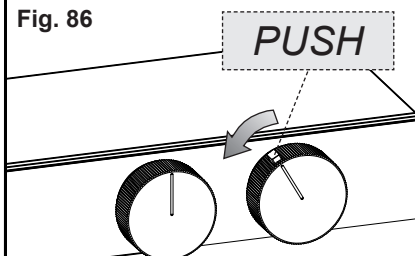

Fig. 86



50°C  
↑  
38°C



Fig. 87

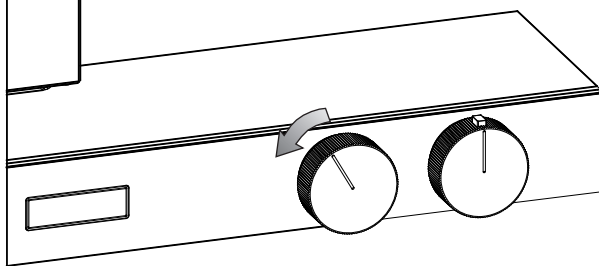

MIN  
MAX

Fig. 88

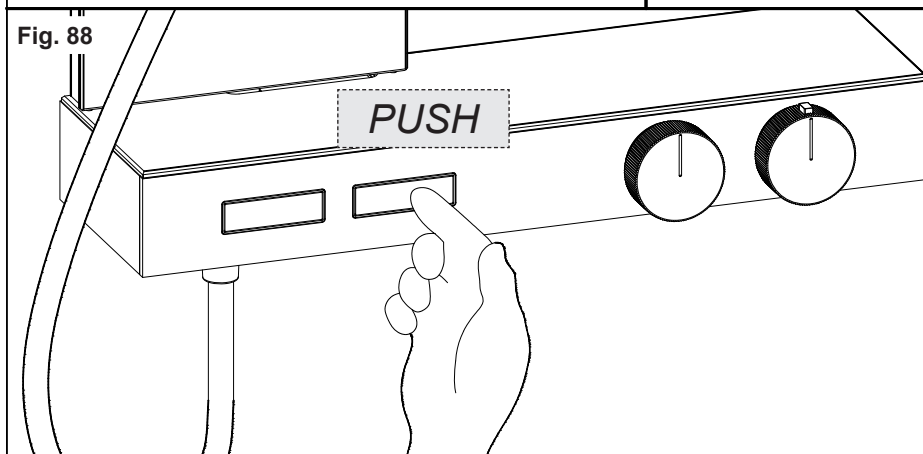

Fig. 89

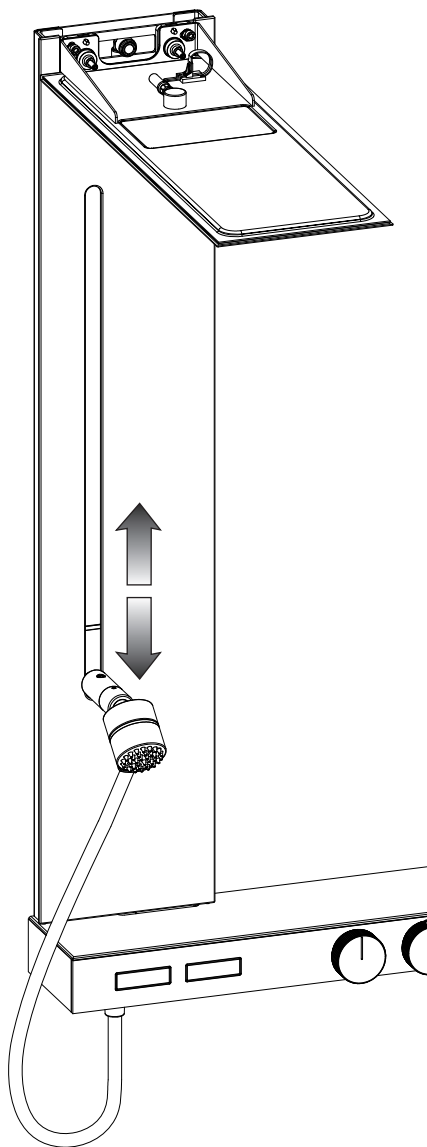

Fig. 90

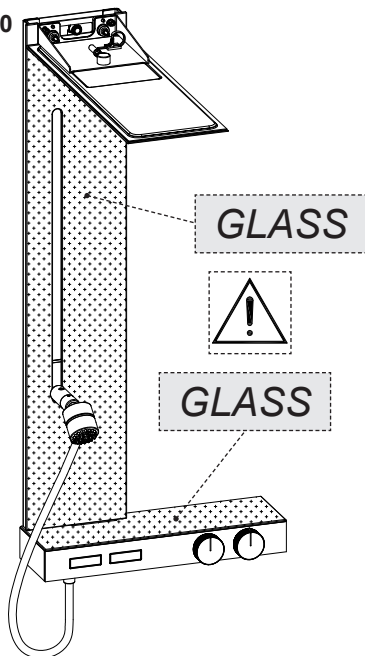
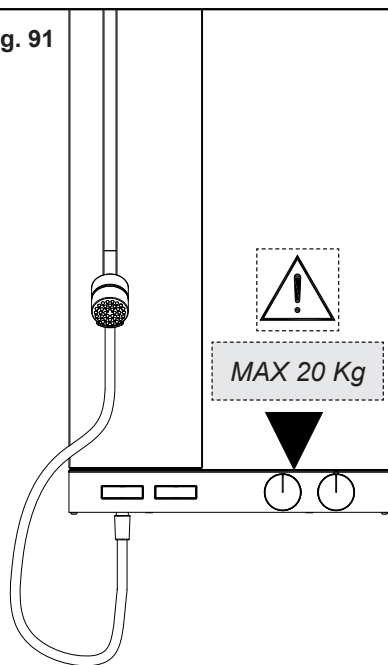

Fig. 91





#### **MANUTENZIONE**

- Nel caso sia necessario sostituire uno o più componenti, contattare un rivenditore autorizzato o visitare il sito [WWW.GESSI.COM](http://WWW.GESSI.COM)
- Affidare la manutenzione del prodotto a personale qualificato

#### **MAINTENANCE**

- Should it be necessary to replace one or more components, contact an authorized retailer or visit [WWW.GESSI.COM](http://WWW.GESSI.COM)
- Product maintenance should be made only by qualified staff

#### **ENTRETIEN**

- S'il est nécessaire de remplacer un ou plusieurs composants, contacter un centre autorisé ou visiter le site [WWW.GESSI.COM](http://WWW.GESSI.COM)
- L'entretien du produit ne doit être effectué que par du personnel qualifié

#### **WARTUNG**

- Falls das Auswechseln von einem oder mehreren Bestandteilen erforderlich wird, kontaktieren Sie bitte einen autorisierten Fachhandel oder besuchen Sie unsere Website unter [WWW.GESSI.COM](http://WWW.GESSI.COM)
- Die Instandhaltung des Produktes sollte nur qualifiziertem Personal anvertraut werden.

#### **MANUTENCIÓN**

- En el caso de que sea necesario remplazar uno o más componentes, contacten con un revendedor autorizado o visiten el sitio [WWW.GESSI.COM](http://WWW.GESSI.COM)
- Encarguen sólo a personal calificado para el mantenimiento del producto

#### **ОБСЛУЖИВАНИЕ**

- В случае если будет необходимо заменить один или несколько компонентов, обратитесь к авторизованному дистрибьютору или посетите веб-сайт [WWW.GESSI.COM](http://WWW.GESSI.COM)
- Обслуживание изделия должен выполнить квалифицированный персонал.

#### **ΣΥΝΤΗΡΗΣΗ**

- Σε περίπτωση που είναι απαραίτητο να αντικαταστήσετε ένα ή περισσότερα εξαρτήματα, επικοινωνήστε με ένα εξουσιοδοτημένο κατάστημα πώλησης ή επισκεφθείτε τον ιστότοπο [WWW.GESSI.COM](http://WWW.GESSI.COM)
- Εμπιστευθείτε τη συντήρηση του προϊόντος σε διαπιστευμένο προσωπικό

#### **保养**

- 若需替换一个或者多个部件，请联系授权分销商或浏览[WWW.GESSI.COM](http://WWW.GESSI.COM)网站
- 请让合格人士负责产品保养工作

Fig. 1

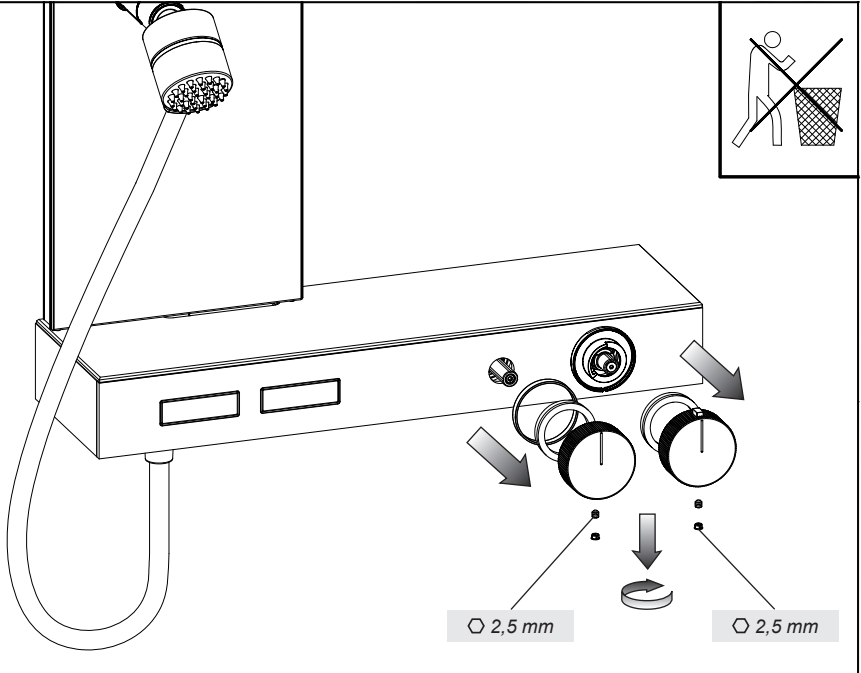
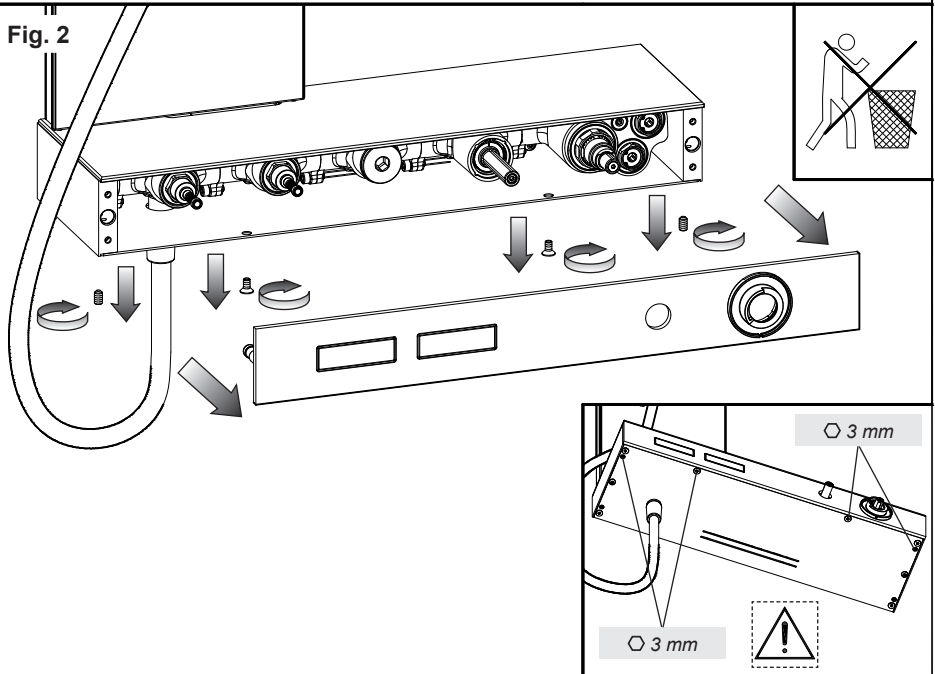

Fig. 2



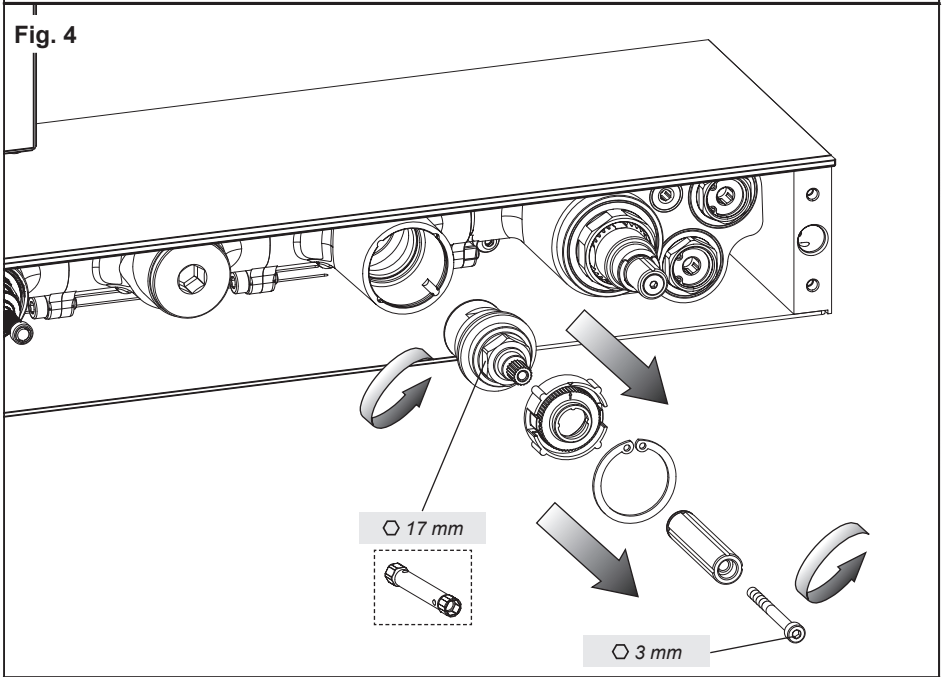
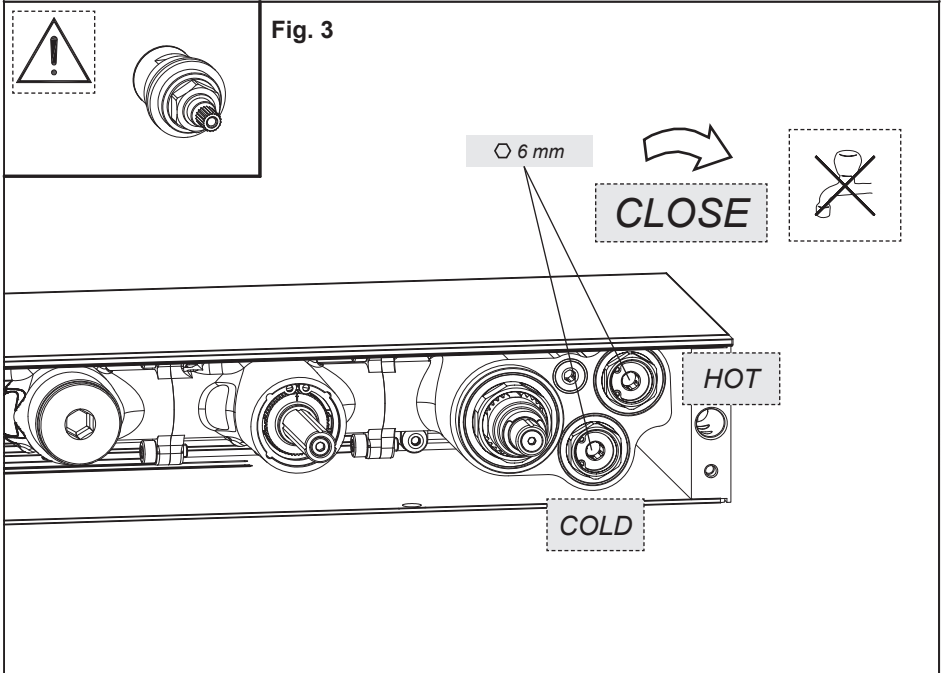

Fig. 5

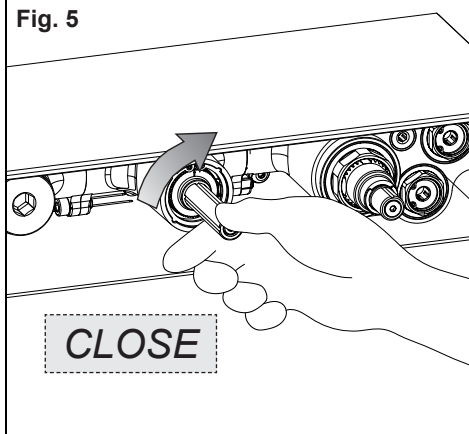

Fig. 6

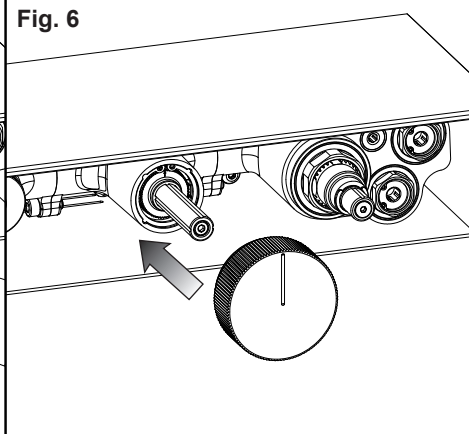

Fig. 7

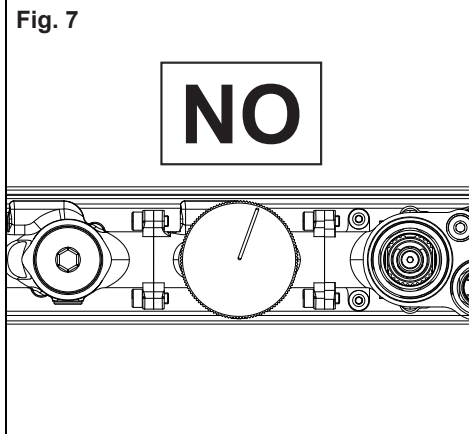

Fig. 8

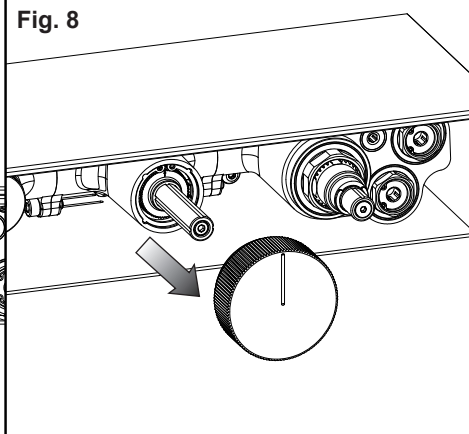

Fig. 9

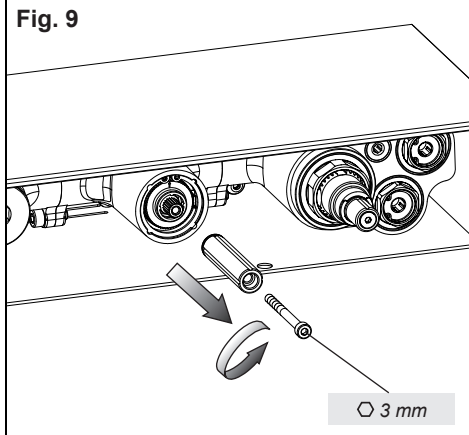

Fig. 10

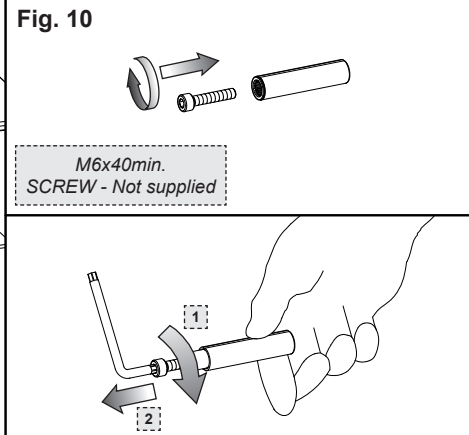

Fig. 11

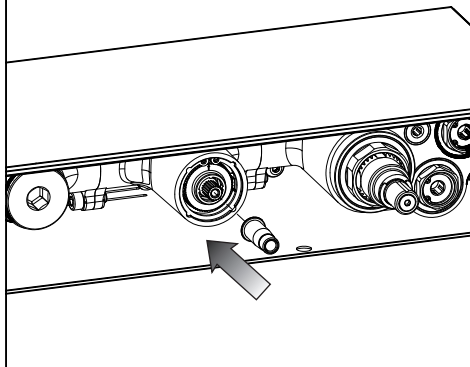

Fig. 12

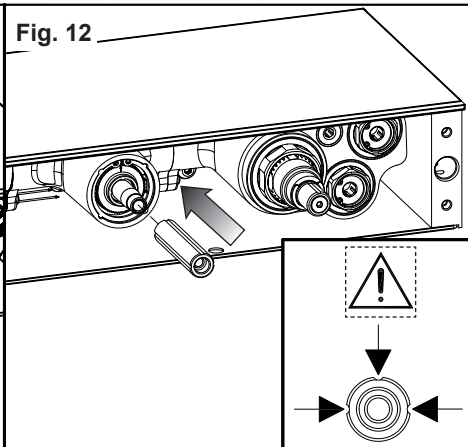

Fig. 13

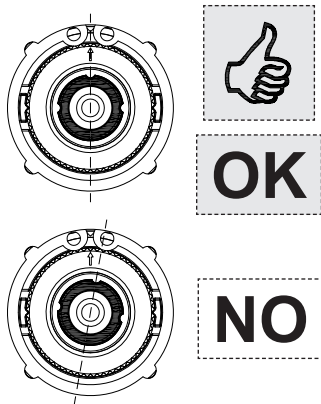

Fig. 14

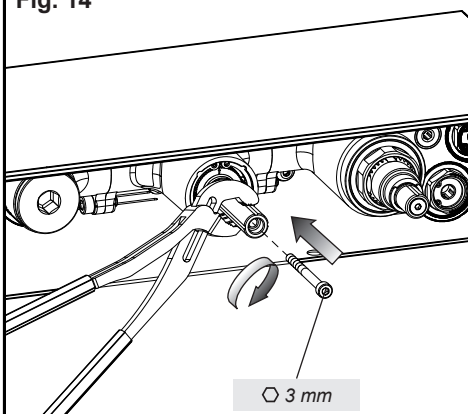

Fig. 15

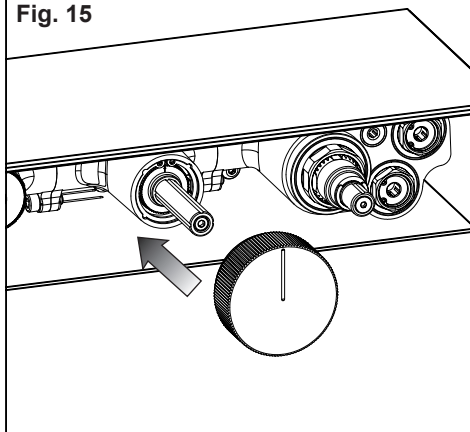
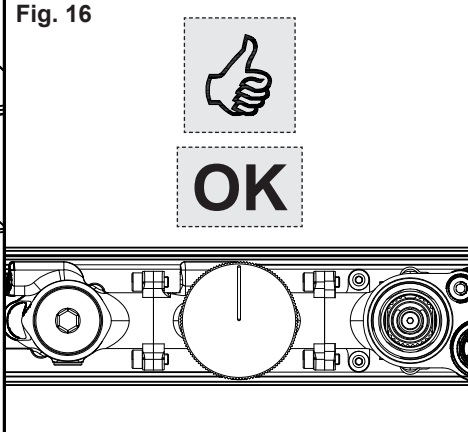
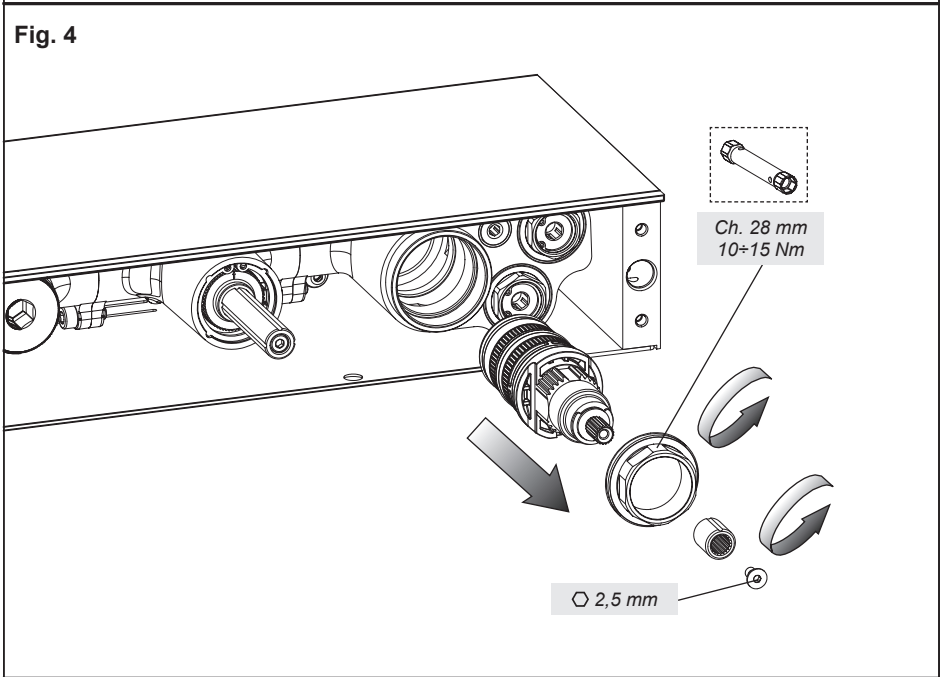
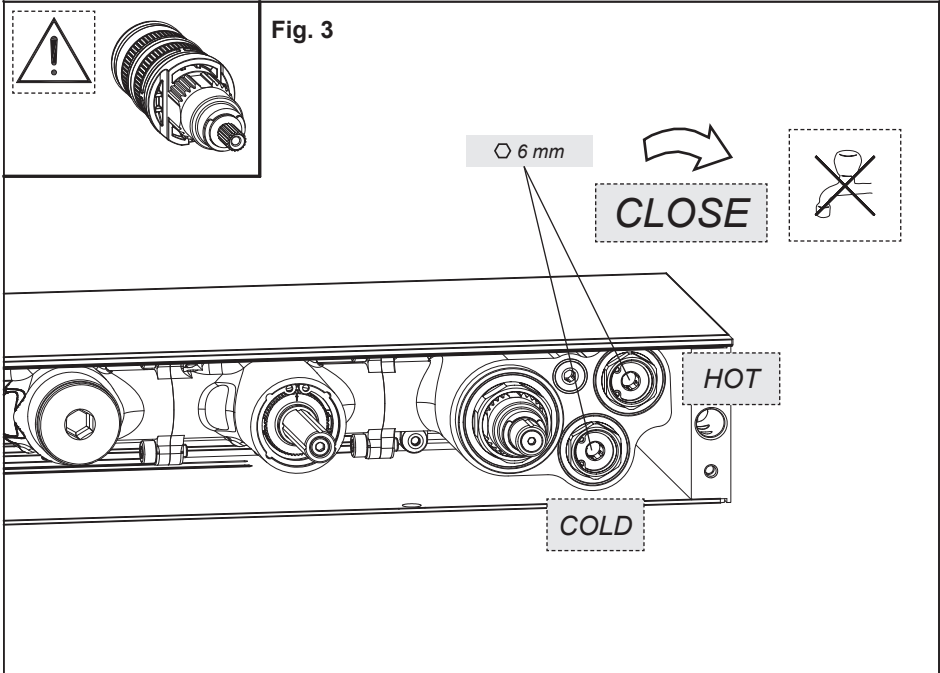
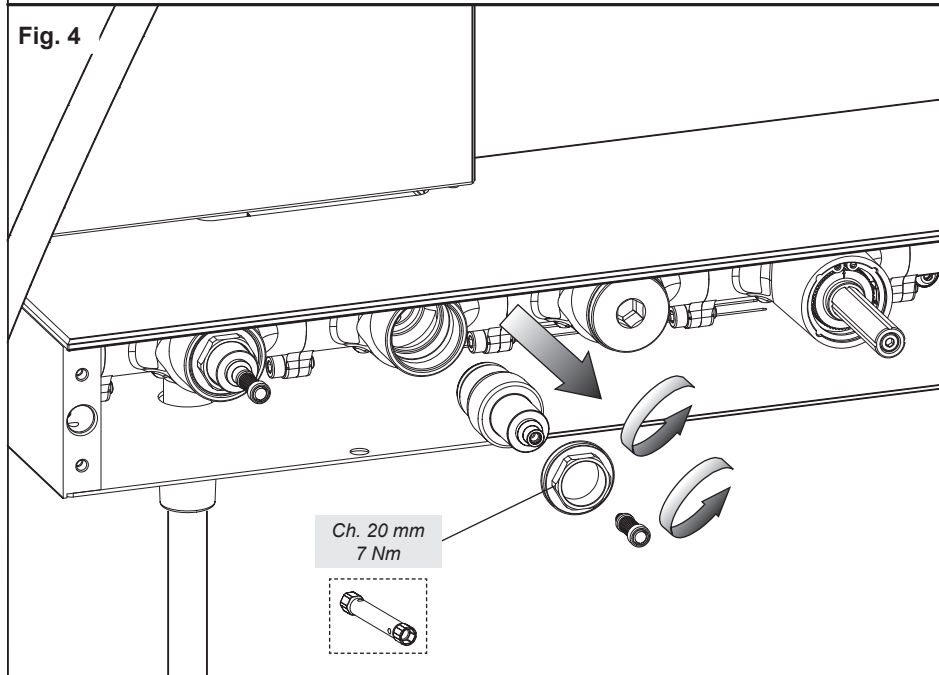
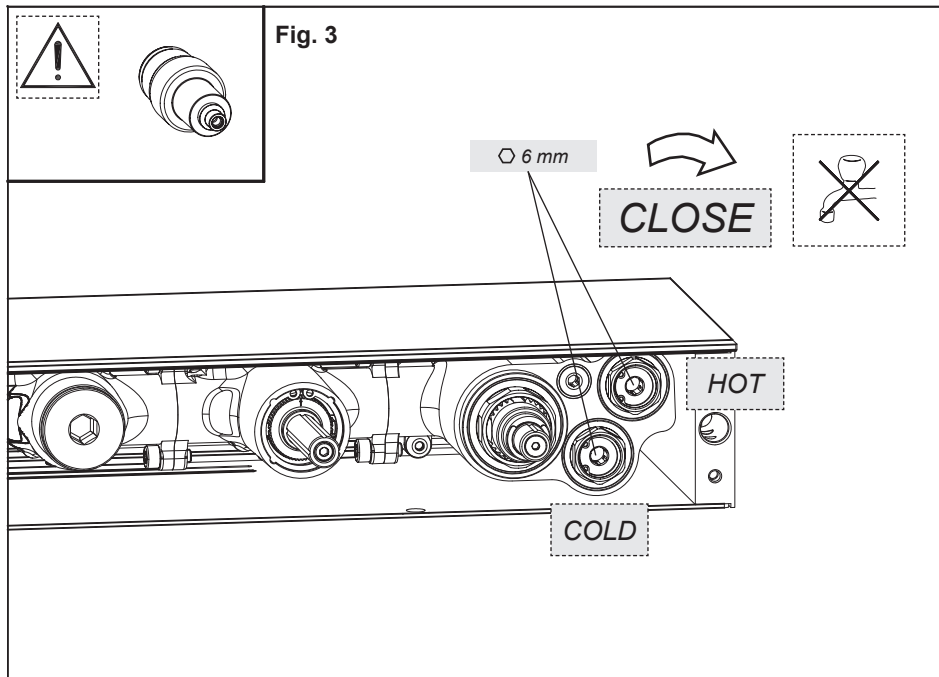
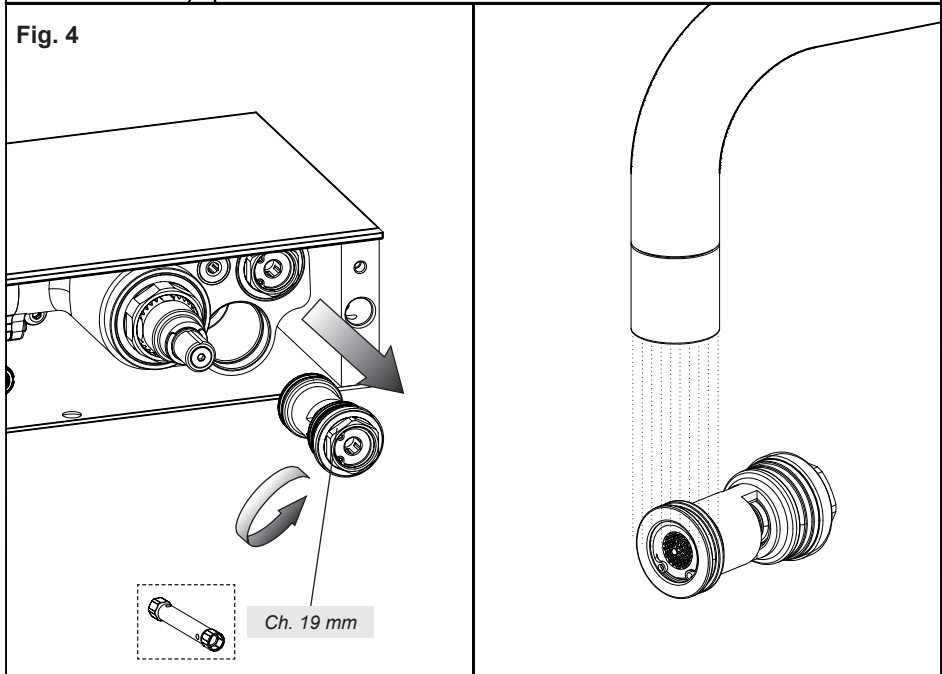
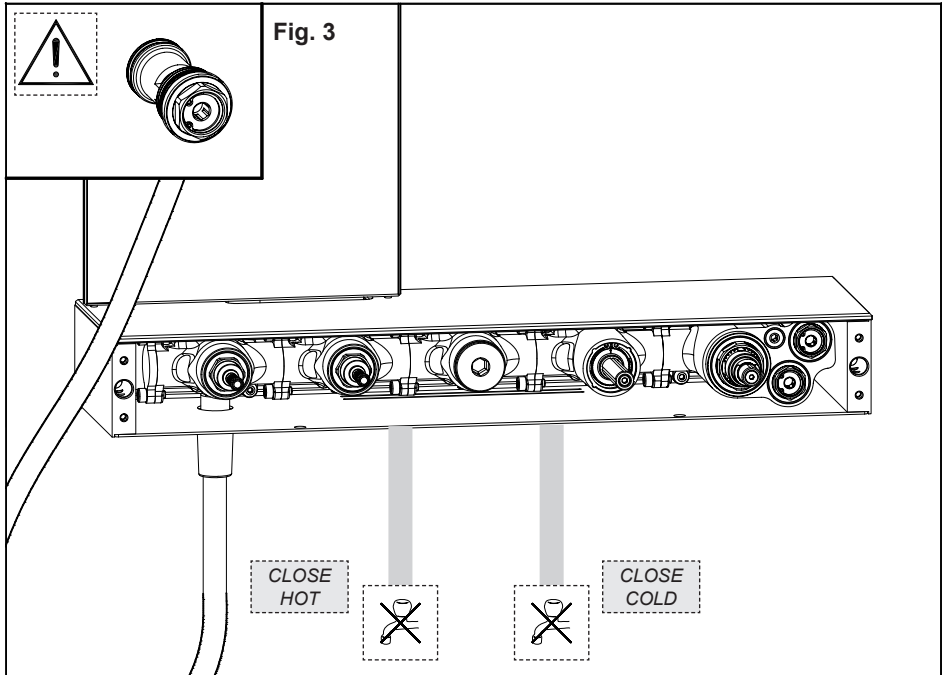

Fig. 16









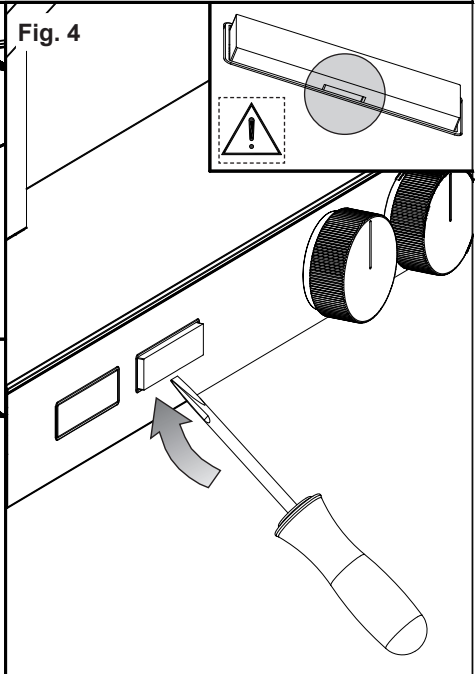
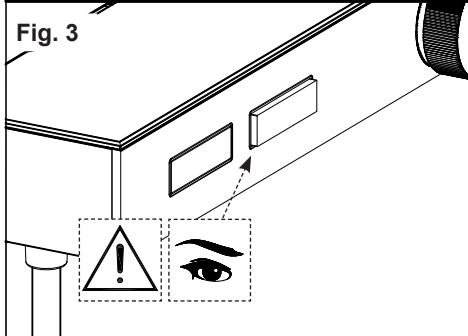
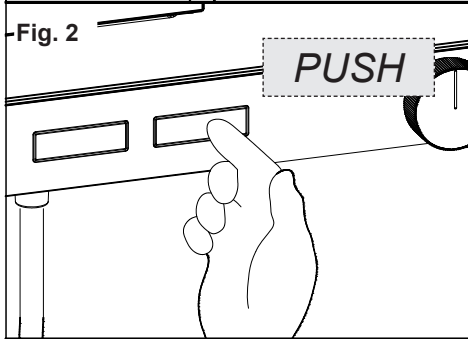
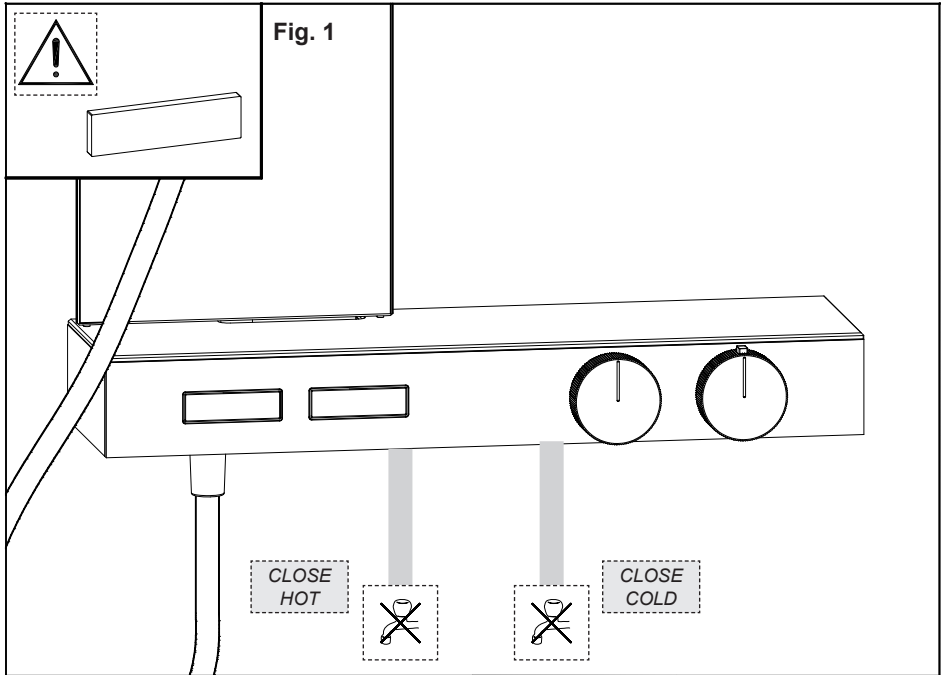

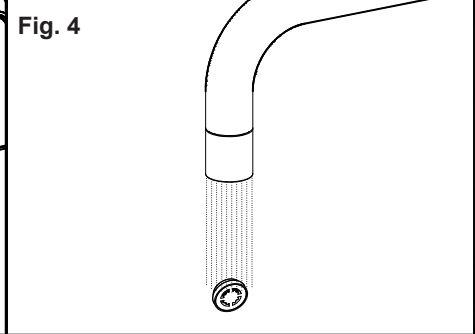
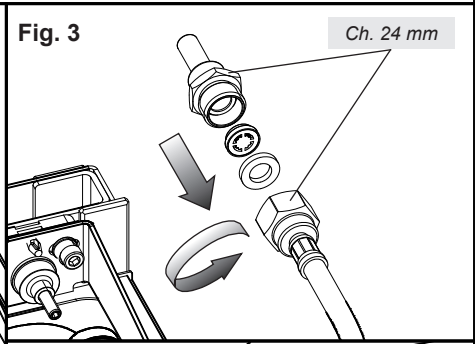
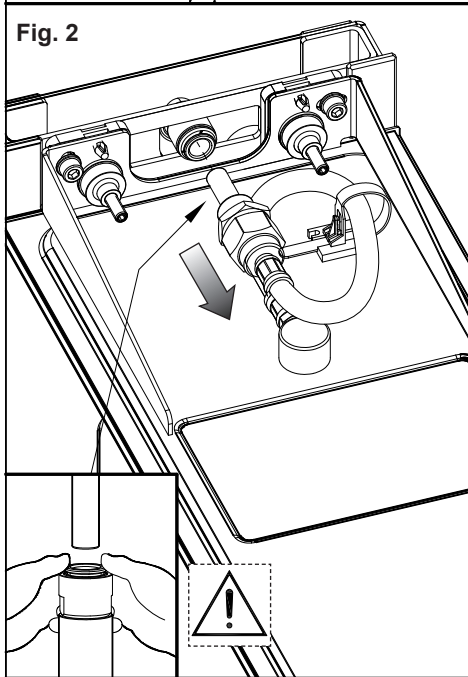
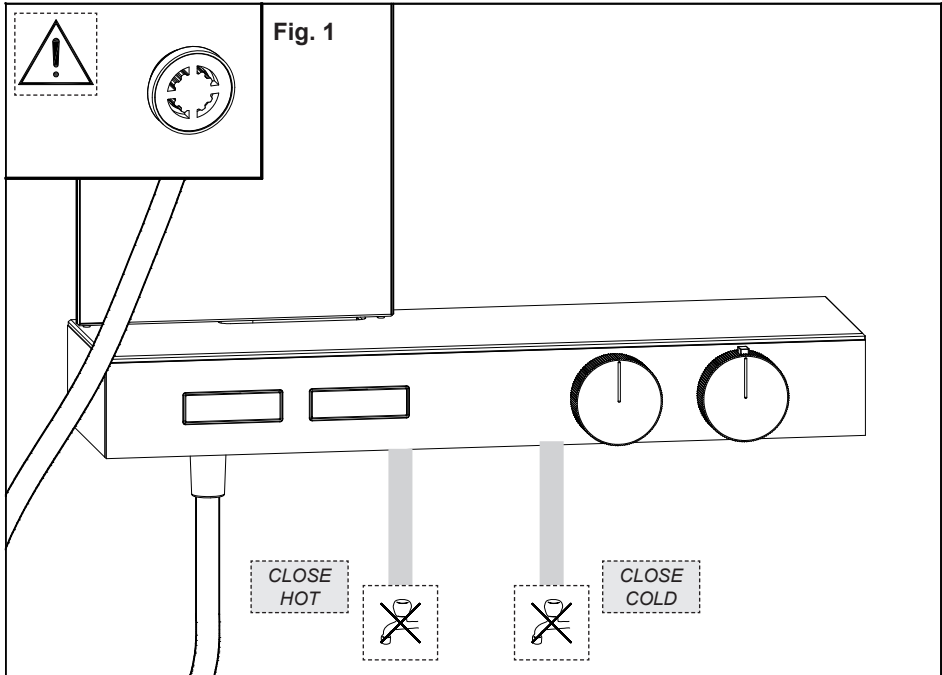

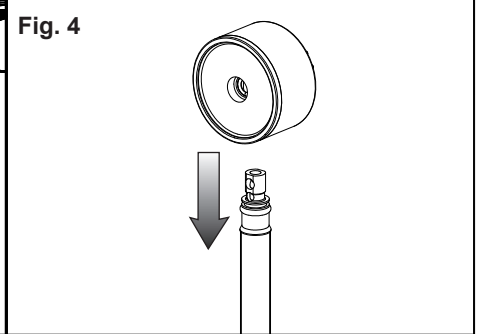
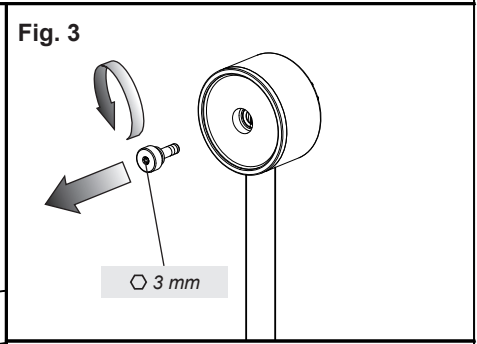
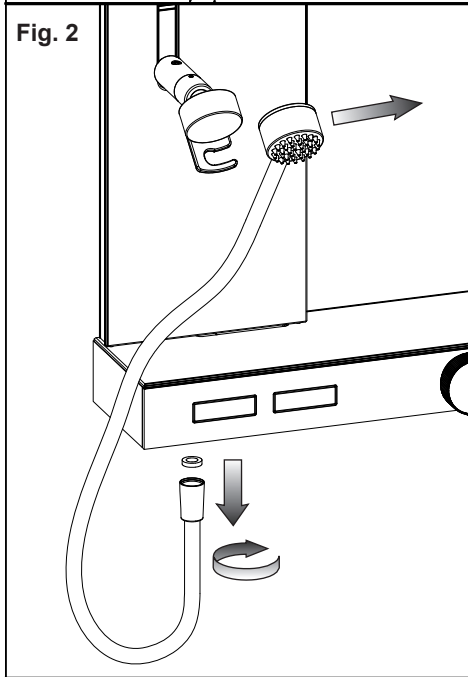
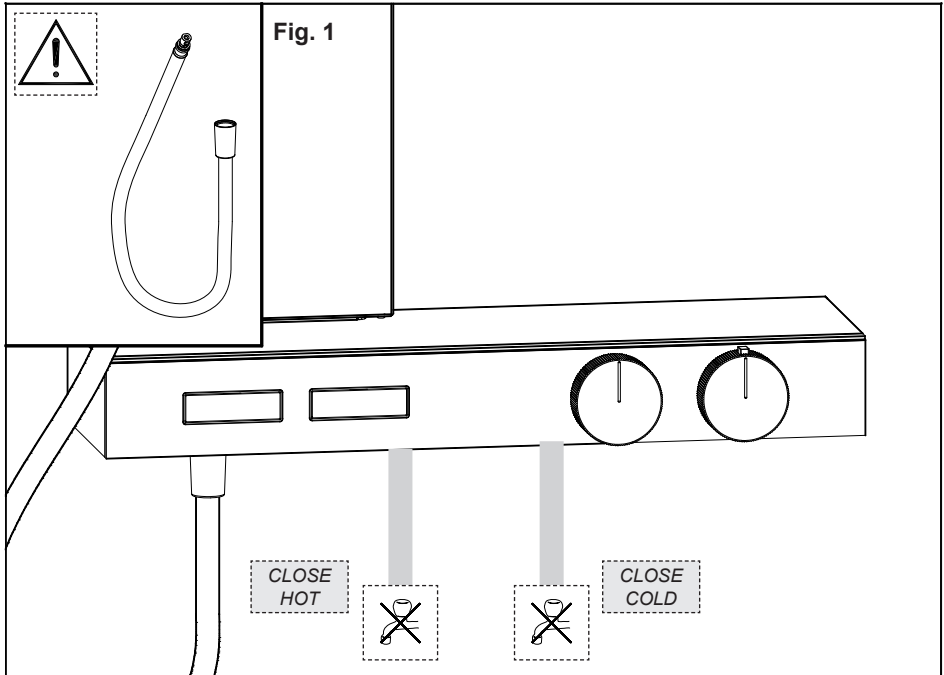

A series of horizontal dotted lines for writing notes, spanning the width of the page.

A series of horizontal dotted lines for writing notes, spanning the width of the page.

A series of horizontal dotted lines for writing notes, spanning the width of the page.

A series of horizontal dotted lines for writing notes, spanning the width of the page.

A series of horizontal dotted lines for writing notes, spanning the width of the page.



